

PACKET SUPPLEMENT

Regular Council Meeting, Monday, June 11, 2018, 7:00 P.M.

Paul D. Bueche Municipal Building, 8083 Civic Drive Swartz Creek, Michigan 48473

- ✓ **DAVAL DRIVE STREET LIGHTING UPGRADE WORK ORDER & INVOICE** (*Business Item*)
To complete the paperwork side of the lighting changes, we have one final step. Step one was to apportion funds and approve the concept. Step two approved the service agreement. Now, Consumers Energy desires affirmation of the work orders to remove and replace the specific poles. The work orders and a resolution are attached. This order does not reflect any new expenditures, service changes, or project amendments.

Resolution No. 1806118-8J RESOLUTION TO APPROVE CONSUMERS ENERGY LIGHTING REMOVAL AND REPLACEMENT WORK ORDER

Motion by Councilmember: _____

WHEREAS, the street lights in the city are owned and operated by Consumers Energy Company (CE), a Michigan utility with principle offices located at One Energy Plaza, Jackson MI, 49201; and

WHEREAS, CE is the sole provider of street lights, electrical delivery, and maintenance on said lights in the County of Genesee, including Swartz Creek City; and

WHEREAS, CE supplies street lighting services to the city under a current standard street lighting contract which outlines specific fixture counts and types, said contract restated on November 1, 2014 and revised and approved by the city council as recently as April 24, 2017; and

WHEREAS, the City approved additional changes to the street lighting services agreement that include changes to lighting types and subsequent billing for LED and decorative lighting; and

WHEREAS, Consumers Energy now seeks affirmation of the work orders to remove the existing lighting and install new lighting in accordance with the restated and amended lighting contract, as well as engineered plans for the reconstruction of Daval Drive.

NOW THEREFORE, BE IT RESOLVED, it is hereby deemed advisable to authorize Consumers Energy Company to make changes in the lighting service as provided in the Standard Lighting Contract between the Company and the City of Swartz Creek, dated November 1, 2014, updated June 6, 2018, in accordance with the Authorization for Change in Standard Lighting Contract dated June 6, 2018.

BE IT FURTHER RESOLVED, the Treasurer is authorized and directed to make payment to Consumers Energy in the amount invoiced, \$23,760.

BE IT FURTHER RESOLVED, that the city agrees to the terms and conditions of forms 547 and others as included in the city council packet of June 11, 2018 and further directs the Clerk to execute said forms, resolutions, and agreements that represent the aforementioned terms and conditions.

Second by Councilmember: _____

Voting For: _____

Voting Against: _____

CEM Support Center

Consumers Energy, CEM Support Center, Lansing Service Center, Rm. 122, 530 W. Willow St., P.O. Box 30162 Lansing, MI 48909-7662

June 7, 2018

NOTIFICATION #:
1041666515

CITY OF SWARTZ CREEK
8083 CIVIC DR
SWARTZ CREEK, MI 48473-1377

REFERENCE: DAVAL DR, SWARTZ CREEK

Dear Valued Customer,

Thank you for contacting Consumers Energy for your energy needs. Please note the Notification Number above and include it on any correspondence you send. Please note the Account Number, located above the Account Name on your invoice, when submitting payment.

Enclosed for approval and signature is the original Authorization for Change and Resolution covering the replacement and/or installation of streetlight(s). In conjunction with the work, a non-refundable payment of \$100.00 per luminaire is required.

A monthly energy charge associated with this lighting installation for 1 Luminaire(s) is approximately
This charge is subject to change based on current rates. After the installation is complete, you will begin receiving a separate monthly bill for the above energy charge. You are responsible for the final restoration.

The estimated cost for your energy request is as follows:

Non Refundable Agreement for Installation of Electric Facilities:

Winter Construction Costs:	\$ -
Installation Charge (\$100.00 per Luminaire):	\$ 23,760.00
Additional Costs	
Total Estimated Cost:	\$ 23,760.00
Less Prepayment Received:	\$ -
Total Estimated Cost Due:	\$ 23,760.00

Please sign and return the original Authorization for Change and Resolution in the enclosed self-addressed envelope or email to: POBoxCEServiceRequest@cmsenergy.com. Payment in full is required before the installation can be scheduled for construction.

Please review all attached materials carefully and direct inquiries for your request to:

KERRY A SNIDER at 810-760-3335

MISS DIG System, Inc.
1-800-482-7171

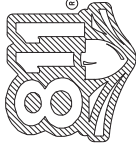

GENESSEE CO
GAINES TWP
T06 R55 SEC.02

UNDERGROUND LEGEND

1. Single-phase primary
 2. Three-phase primary
 3. Three-phase secondary
 4. Single-phase secondary
 5. Three-phase power secondary
 6. Three-phase power secondary
 7. Three-phase power secondary
 8. Combination lighting and power service
 9. Three-phase power service
 10. Streetlighting conductor (2/C-10 CU)
 11. Streetlighting conductor (2/C-18 AL)
 12. Covered neutral conductor for ducts
 13. Streetlighting conductor (2/C-10 AL)
- CONDUIT**
- 14. 2" Plastic
 - 15. 3" Plastic
 - 16. 4" Plastic
 - 17. 2" Steel
 - 18. 3" Steel
 - 19. 4" Steel
 - 20. 6" Steel
- PROP. ELEC. CONDUCTORS ONLY**
- 21. 2" Plastic
 - 22. 3" Plastic
 - 23. 4" Plastic
 - 24. 2" Steel
 - 25. 3" Steel
 - 26. 4" Steel
 - 27. 6" Steel
- PROP. ELEC. GAS AND TELECOMMUNICATIONS**
- 28. 2" Plastic
 - 29. 3" Plastic
 - 30. 4" Plastic
 - 31. 2" Steel
 - 32. 3" Steel
 - 33. 4" Steel
 - 34. 6" Steel
- EXIST. ELEC. CONDUCTORS ONLY**
- 35. 2" Plastic
 - 36. 3" Plastic
 - 37. 4" Plastic
 - 38. 2" Steel
 - 39. 3" Steel
 - 40. 4" Steel
 - 41. 6" Steel
- FUTURE ELECTRIC TRENCH**
- 42. 2" Plastic
 - 43. 3" Plastic
 - 44. 4" Plastic
 - 45. 2" Steel
 - 46. 3" Steel
 - 47. 4" Steel
 - 48. 6" Steel

JOB PURPOSE STATEMENT:
SMARTZ CREEK CONDUITING, ROAD W/ HPS COBBRA HEAD LIGHTING AND INSTALLING NEW LED LIGHTS.

CONDUIT NOTE:
GENERAL CONTRACTOR INSTALLING CONDUIT IN THE SPLIT POLE LOCATIONS.
MIN. 2" SCH 40 GRAY ELECTRICAL CONDUIT WITH PULL ROPE.

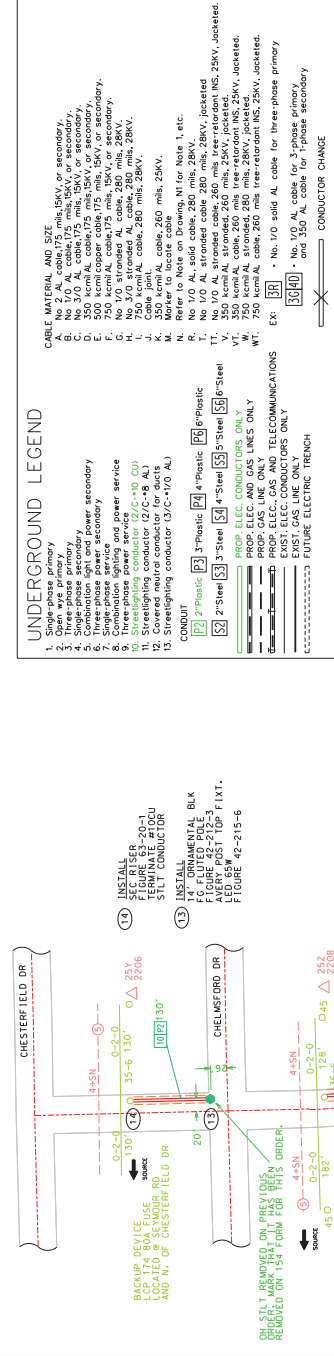

CABLE MATERIAL AND SIZE

- A. No. 1/0 Al. cable, 175 mils, 15kV, or secondary.
- B. No. 1/0 Al. cable, 175 mils, 15kV, or secondary.
- C. No. 1/0 Al. cable, 175 mils, 15kV, or secondary.
- D. No. 1/0 Al. cable, 175 mils, 15kV, or secondary.
- E. 500 kcmil copper cable, 175 mils, 15kV, or secondary.
- F. No. 1/0 Al. cable, 175 mils, 15kV, or secondary.
- G. No. 1/0 Al. cable, 175 mils, 15kV, or secondary.
- H. No. 1/0 Al. cable, 175 mils, 15kV, or secondary.
- I. No. 1/0 Al. cable, 175 mils, 15kV, or secondary.
- J. Cable joint, cable, 280 mils, 28kV.
- K. 350 kcmil Al. cable, 280 mils, 28kV.
- L. 350 kcmil Al. cable, 280 mils, 28kV.
- M. Refer to Note on Drawing, N1 for Note 1, etc.
- N. No. 1/0 Al. solid cable, 280 mils, 28kV.
- O. No. 1/0 Al. solid cable, 280 mils, 28kV.
- P. No. 1/0 Al. solid cable, 280 mils, 28kV.
- Q. No. 1/0 Al. solid cable, 280 mils, 28kV.
- R. No. 1/0 Al. solid cable, 280 mils, 28kV.
- S. No. 1/0 Al. solid cable, 280 mils, 28kV.
- T. No. 1/0 Al. solid cable, 280 mils, 28kV.
- V. 350 kcmil Al. stranded, 280 mils, 28kV, jacketed.
- W. 350 kcmil Al. stranded, 280 mils, 28kV, jacketed.
- X. 350 kcmil Al. stranded, 280 mils, 28kV, jacketed.
- Y. 350 kcmil Al. stranded, 280 mils, 28kV, jacketed.
- Z. 350 kcmil Al. stranded, 280 mils, 28kV, jacketed.
- WT. 750 kcmil Al. cable, 280 mils, 28kV, jacketed.

EX: BR No. 1/0 solid Al. cable for three-phase primary and 350 Al. cable for 1-phase secondary

CONDUCTOR CHANGE

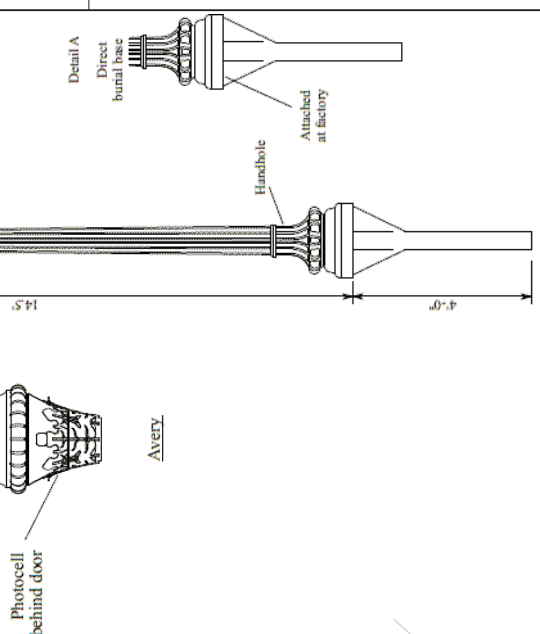

CONSUMERS ENERGY CONTACTS	
DEPARTMENT	ALTERNATE
DESIGNER	JOEY GRAPPIN
COORDINATOR	KERRY SNIDER
STAKED	YES <input type="checkbox"/> NO <input type="checkbox"/>
TREES	YES <input type="checkbox"/> NO <input type="checkbox"/>
TILE NUMBER	0855022201
# OF RIGS	1
DATE	08/26/2011
PROJECT NAME	SMARTZ CREEK
PROJECT NUMBER	810-160-3262
PROJECT DATE	8/26/11
PROJECT TYPE	ESC
PROJECT LOCATION	DAVAL DR, SRTZ, STLT PROJECT ESC LED
PROJECT NUMBER	810-160-3335
PROJECT DATE	8/26/11
PROJECT TYPE	ESC
PROJECT LOCATION	DAVAL DR, SRTZ, STLT PROJECT ESC LED
PROJECT NUMBER	810-160-3335
PROJECT DATE	8/26/11
PROJECT TYPE	ESC
PROJECT LOCATION	DAVAL DR, SRTZ, STLT PROJECT ESC LED

CONSTRUCTION CERTIFICATION	
Work was constructed as Engineered or Changed as Indicated.	
Unauthorized materials/changes indicated in drawings are in Direct Charge of Work	
Specified	Completed
Dates Shredded	
MISS DIG NUMBER	
DATE	

CEM Support Center

Consumers Energy, Lansing Service Center, Rm. 122, 530 W. Willow St., P.O. Box 30162 Lansing, MI 48909-7662

<p>PLEASE RETURN THE CHECKED DOCUMENTS BELOW TO CONSUMERS ENERGY IN THE ENVELOPE PROVIDED</p>	
<p>TO EXPEDITE SERVICE, RETURN VIA EMAIL TO:</p>	
<p>POBoxCEServiceRequest@cmsenergy.com</p>	
<input type="checkbox"/>	<p>SIGNED ELECTRIC CONTRACT (Please return all pages of contracts) (Form 93, Form 94 and Form 95 - 2 Page Document Each) (Form 861, Form 862 and Form 230 - 4 Page Document Each)</p>
<input checked="" type="checkbox"/>	<p>PAYMENT WITH INVOICE STUB (TOP STUB IS REQUIRED FOR PROCESSING)</p>
<input type="checkbox"/>	<p>REQUEST FOR ELEVATED CUSTOMER DELIVERY PRESSURE</p>
<input checked="" type="checkbox"/>	<p>STANDARD LIGHTING CONTRACT (MUST BE CERTIFIED BY CLERK)</p>
<input type="checkbox"/>	<p>SIGNED CUSTOMER ATTACHMENT PROGRAM (CAP) CONTRACT (PLEASE ENSURE TO CHECK PAYMENT OPTION ON CONTRACT)</p>
<input checked="" type="checkbox"/>	<p>GO READY FORM (FORM 1250) TO EXPEDITE SERVICE, RETURN VIA EMAIL TO: POBoxCEServiceRequest@cmsenergy.com</p>
<input type="checkbox"/>	<p>SITE READY PHOTO(S) TO EXPEDITE SERVICE, RETURN VIA EMAIL TO: POBoxCEServiceRequest@cmsenergy.com</p>
<input type="checkbox"/>	<p>OTHER:</p>
<p>NOTIFICATION REFERENCE NUMBERS</p>	
<p>ELECTRIC SERVICE NOTIFICATION:</p>	
<p>GAS SERVICE NOTIFICATION:</p>	
<p>ELECTRIC OH DISTRIBUTION NOTIFICATION:</p>	
<p>ELECTRIC UG DISTRIBUTION NOTIFICATION:</p>	
<p>GAS MAIN NOTIFICATION:</p>	
<p>STREETLIGHT NOTIFICATION:</p>	<p>1041666515</p>



Account Number 300013313014
Account Name CITY OF SWARTZ CREEK
Address 8083 CIVIC DR
 SWARTZ CREEK, MI 48473

Invoice Number 9313012605
PO Number
PO Date
Bill Date 06/07/18
DUE DATE 06/21/18

CITY OF SWARTZ CREEK
 8083 CIVIC DR
 SWARTZ CREEK MI 48473-1377

Comments: DAVAL DR - SWARTZ CREEK - STREETLIGHTING - NOTIFICATION NUMBER (s): - - - - -
 1041666515 -
 Contact our secure credit/debit card payment center at 866-329-9593 to make a payment or visit us at
 ConsumersEnergy.com/waystopay to view other convenient payment options.

Item	Description	Quantity	Unit Price	Amount
40010403	Electric Streetlights-CIAC DAVAL DR STREETLIGHT PROJECT	1.0 EA	\$23,760.00	\$23,760.00
Payment Terms:				Due by: 06/21/18
			TOTAL DUE:	\$23,760.00
PLEASE ENCLOSE THE BOTTOM PORTION OF THIS INVOICE WITH YOUR PAYMENT. THE ACCOUNT NUMBER IS NECESSARY TO ENSURE YOUR PAYMENT IS PROPERLY CREDITED. THANK YOU				

Contact Information: KERRY A SNIDER -810-760-3335 -

Consumers Energy is regulated by the Michigan Public Service Commission, Lansing, Michigan.

Please detach this stub and return it with your payment



CONSUMERS ENERGY
 CEM Support Ctr - Lansing RM 122
 PO Box 30162
 Lansing, MI 48909-7662

PREPAYMENT REQUEST
 CITY OF SWARTZ CREEK
 8083 CIVIC DR
 SWARTZ CREEK MI 48473-1377

Due Date	Total Due
06/21/18	\$23,760.00
Amount Enclosed	\$



**AUTHORIZATION FOR CHANGE IN
STANDARD LIGHTING CONTRACT
(COMPANY-OWNED) FORM 547**

Contract Number: 100000431294

Consumers Energy Company is authorized as of 6/6/2018, by the City of SWARTZ CREEK, to make changes, as listed below, in the lighting system(s) covered by the existing Standard Lighting Contract between the Company and the City of SWARTZ CREEK, dated 6/6/2018.

Lighting Type:

General Service Unmetered Lighting Rate GUL, Standard High Intensity Discharge

Notification Number(s):

1041666515

Construction Work Order Number(s):

DESIGN #10921100

Except for the changes in the lighting system(s) as herein authorized, all provisions of the aforesaid Standard Lighting Contract dated 6/6/2018 shall remain in full force and effect.

City of SWARTZ CREEK

By:

(Signature)

(Printed)

Its

(Title)

This Agreement may be executed and delivered in counterparts, including by a facsimile or an electronic transmission thereof, each of which shall be deemed an original. Any document generated by the parties with respect to this Agreement, including this Agreement, may be imaged and stored electronically and introduced as evidence in any proceeding as if original business records. Neither party will object to the admissibility of such images as evidence in any proceeding on account of having been stored electronically.

RESOLUTION

RESOLVED, that it is hereby deemed advisable to authorize Consumers Energy Company to make changes in the lighting service as provided in the Standard Lighting Contract between the Company and the City of SWARTZ CREEK, dated 6/6/2018, in accordance with the Authorization for Change in Standard Lighting Contract dated 6/6/2018,

heretofore submitted to and considered by this commission council board ;and

RESOLVED, further, that the _____ Clerk be and are authorized to execute such authorization for change on the behalf of the City.

STATE OF MICHIGAN
COUNTY OF Genesee

I, _____, Clerk of the City of SWARTZ CREEK, do hereby certify that the foregoing resolution was duly adopted by the commission council board of said municipality, at the meeting held on _____.

Dated:

Municipal Customer Type: City

GENERAL SERVICE UNMETERED LIGHTING RATE GUL, STANDARD HIGH INTENSITY DISCHARGE

<i>Number of Luminaires</i>	<i>Nominal Watts</i>	<i>Luminaire Type</i>	<i>Fixture Type</i>	<i>Fixture Style</i>	<i>Install Remove</i>	<i>Location</i>
1	<u>100</u>	<u>HPS</u>	<u>Cobrahead</u>	<u>Non-Cutoff</u>	<u>Remove</u>	5173 DAVAL DR
1	<u>100</u>	<u>HPS</u>	<u>Cobrahead</u>	<u>Non-Cutoff</u>	<u>Remove</u>	DAVAL DR & OAKVIEW DR
1	<u>100</u>	<u>HPS</u>	<u>Cobrahead</u>	<u>Non-Cutoff</u>	<u>Remove</u>	DAVAL DR & WORCHESTER DR

GO-READY Checklist
Natural Gas & Electric Request



Thank you for contacting Consumers Energy for your energy needs. This form is a requirement for scheduling your service installation. You will receive a contact from Consumers Energy one to two days before our scheduled arrival. If it is deemed any of the requirements are not met upon our arrival, Consumers Energy reserves the right to reschedule your job.

Please return completed Checklist to one of the following (e-mail preferred):
 E-mail: poboxceservicerequest@cmsenergy.com Fax: 517-374-2424 Mail: Consumers Energy Service Request, 530 W Willow St, Lansing, MI 48906

Notification #: 1041666515

Service Address: DAVAL DR, SWARTZ CREEK

Please check all requirements on the checklist below before returning this document. Providing accurate information upon completion when submitting your form helps assure construction execution upon crew arrival.

- | | <u>YES</u> | <u>N/A</u> |
|---|--------------------------|--------------------------|
| 1. Has your payment been submitted to Consumers Energy? | <input type="checkbox"/> | <input type="checkbox"/> |
| 2. Has your gas meter location been clearly marked, and/or your electric meter socket properly installed at the agreed upon location? | <input type="checkbox"/> | <input type="checkbox"/> |
| 3. Has your electric meter been inspected and approved by the local city/township inspector? | <input type="checkbox"/> | <input type="checkbox"/> |
| 4. Is the site within 3 inches of final grade? | <input type="checkbox"/> | <input type="checkbox"/> |
| 5. Is a 12' wide path clear of debris and construction equipment? | <input type="checkbox"/> | <input type="checkbox"/> |
| 6. Site Ready Photo (subdivision services only). Include photo with Checklist. | <input type="checkbox"/> | |

Making Consumers Energy aware of any customer owned, underground facilities present, by clearly identifying and indicating the facility of their location reduces the risk of damages. Locate or expose any privately owned underground facilities or buried obstructions including, but not limited to:

	<u>YES</u>	<u>N/A</u>		<u>YES</u>	<u>N/A</u>
Septic tank (Existing or future)	<input type="checkbox"/>	<input type="checkbox"/>	Underground yard lighting	<input type="checkbox"/>	<input type="checkbox"/>
Drain field (Existing or future)	<input type="checkbox"/>	<input type="checkbox"/>	Sprinkler systems	<input type="checkbox"/>	<input type="checkbox"/>
Well (Existing or future)	<input type="checkbox"/>	<input type="checkbox"/>	Electronic dog fences	<input type="checkbox"/>	<input type="checkbox"/>

Other:

These facilities must be marked with stakes, spray paint or flags. Consumers Energy and/or its agents will not be held responsible for damage that occurs to customer-owned underground facilities that are not properly located and marked before service installation.

After services are installed, excavation will be backfilled. Final restoration is your responsibility.

Thank you for your partnership!

Printed Name:

Signature:

Date: