

**City of Swartz Creek  
AGENDA**

**Regular Council Meeting, Monday February 23, 2009, 7:00 P.M.  
City Hall 8083 Civic Drive, Swartz Creek Michigan 48473**

1. **CALL TO ORDER:**
2. **INVOCATION AND PLEDGE OF ALLEGIANCE:**
3. **ROLL CALL:**
4. **MOTION TO APPROVE MINUTES:**
  - 4A. Regular Council Meeting of February 9, 2009 MOTION Pg. 8,14-24
5. **APPROVE AGENDA**
  - 5A. Proposed / Amended Agenda MOTION Pg. 8
6. **REPORTS & COMMUNICATIONS:**
  - 6A. [City Manager's Report](#) (Agenda Item) MOTION Pg. 8,2-7
  - 6B. Monthly Fire Report Pg. 25-34
  - 6C. Consumer's Energy Easement, Drawing (Agenda Item) Pg. 35-37
  - 6D. Genesee County Re-Cycling, Annual Donation (Agenda Item) Pg. 38-40
  - 6E. Sr. Center Addition, Concept Drawings, Cost Opinions (Agenda Item) Pg. 41-48
  - 6F. Verizon FOIA Request Pg. 49-67
  - 6G. MML Claim Denial, Sewer Backup Pg. 68-69
  - 6H. 2010-2013 TIP Applications Pg. 70-87
  - 6I. Cross Connection Control Program, Annual Report Pg. 88-89
  - 6J. Resident Complaint, Surface Water Pg. 90
  - 6K. Consumer's Energy, MPSC Filing Notices Pg. 91-92
  - 6L. County Road Commission Notice, Weight Restrictions (Spring On The Way?) Pg. 93
  - 6M. DDA Mtg Notice Pg. 94
  - 6N. Genesee County Beautification Workshops Pg. 95-98
  - 6O. County "State of the County" Notice Pg. 99
  - 6P. Governor Visit, Stimulus Transportation Notice Pg. 100-102
  - 6Q. Legislative Updates Pg. 103-108
7. **MEETING OPENED TO THE PUBLIC:**
  - 7A. General Public Comments
8. **COUNCIL BUSINESS:**
  - 8A. Grant Easement, Consumer's Energy, Property ID #58-36-400-007 RESO. Pg. 9,35-37
  - 8B. Membership, Genesee County Re-Cycling Coalition RESO. Pg. 10,38-40
  - 8C. Sr. Center Addition Concept RESO. Pg. 11,41-48
  - 8D. NSP Participation DISC. Pg. 7
9. **MEETING OPENED TO THE PUBLIC:**
  - 9A. General Public Comments
10. **REMARKS BY COUNCILMEMBER'S:**
11. **ADJOURNMENT:** MOTION N/A

**City of Swartz Creek**  
**CITY MANAGER'S REPORT**  
Regular Council Meeting of Monday February 23, 2009 7:00 P.M.

**TO:** Honorable Mayor, Mayor Pro-Tem & Council Members  
**FROM:** PAUL BUECHE // City Manager  
**DATE:** 20-February-2009

---

## **OLD / ROUTINE BUSINESS – REVISITED ISSUES / PROJECTS**

- ✓ **PERSONNEL POLICIES & PROCEDURES** (*Status*)  
Pending.
- ✓ **DISASTER, EMERGENCY RESPONSE POLICY COMMITTEE** (*Status*)  
We should be back before the Council for discussion on this in the near future.
- ✓ **VETERANS MEMORIAL** (*Status*)  
Nothing New.
- ✓ **NON-RESIDENT SERVICES STUDY, RAUBINGER BRIDGE** (*Status*)  
The Raubinger Bridge Project has a tentative start date of July 2009.
- ✓ **OVERHEAD UTILITY REORGANIZATION PROJECT** (*Status*)  
As we discussed, the utility companies have lobbied the passing of a number of pieces of legislation that have stripped us of virtually all control of our rights of way. In regards to the aesthetics, we have little power other than to pay for changes. The next step is to get a contractor's quote for the second round of the technical review of the poles. From here, we may have some power by filing complaints on the safety issues. REI is getting a quote together from their survey division and should be back with it shortly. My thinking is to narrow down the inventory to the downtown, Miller & Elms and Bristol Road. This will hold the cost down and we can always go back and pick up additional sections of the City.
- ✓ **MAJOR STREET FUND, TRAFFIC IMPROVEMENTS** (*See Individual Category*)
  - 2010-2013 T.I.P. APPLICATION** (*Status*)  
Pending.
  - BRISTOL ROAD T.I.P. PROJECT, VERIZON INVOICE** (*Status*)  
We have someone's attention here. I have an F.O.I.A. request from Verizon's legal department for records. I have requested a 10-day extension and am working with Mr. Figura on a response. I will keep the Council informed.
  - THREE LANE CONVERSION, STRIPING** (*Status*)  
As we discussed, a conversion to three lanes for Miller east of Elms is not cost feasible. We will be going to bid for a conversion for all of Morrish, being Bristol south to the south City Limits. When we have better cost returns on this, we will look at the feasibility of continuing. Although it appears doubtful, we will keep our eye on the possibility of Economic Stimulus Funds for this project.
  - ELMS ROAD RE-SURFACING PROJECT** (*Status*)  
Completed, with the exception of some minor cleanup work in the spring.

- MORRISH ROAD RE-CONSTRUCTION PROJECT / MEIJER'S** *(Status)*  
 Plans are in place to perform the Morrish Road work in accordance with the Development Agreement with Meijer and the current engineers' plans. There is a complication concerning the design of the Morrish and Bristol Road intersection due to the standards of the Genesee County Road Commission. The project cannot be completed as designed according to GCRC. To construct the intersection to their standards, increased road widths and right-of-way acquisition is required. These needs increase the cost substantially. As such, the project will end at the northern City limits for the time being and the intersection, termed 'phase two' will be completed at a later date. It is hoped that GCRC will negotiate more reasonable standards in the mean time.
- GM-SPO ISLAND CUTS** *(Status)*  
 This project is no longer in the 2009 TIP. The City can still evaluate the cost vs. benefit ratio and include this project in future TIP call for projects.
- LOCAL STREET FUND, TRAFFIC IMPROVEMENTS**
  - 2008 REPAIR ROSTER** *(Status)*  
 Bid results for Chesterfield from Seymour to Winston, Jennie Lane, Worchester from Winston to Daval and Daval from Oakview to Winshall are \$398,154. We have placed all local streets re-surfacing on hold for a bit while we explore funding options.
- TRANSPORTATION ASSET MANAGEMENT EVALUATION** *(Status)*  
 Pending report.
- SEWER REHABILITATION PROJECT, I&I, PENALTIES** *(Status)*  
 Phase II was approved on October 13<sup>th</sup> and will begin shortly. I will keep the Council posted on progress. The manhole rehabilitation program is under contract and work is underway. Included with tonight's packet is an interesting letter of complaint. A homeowner in the woods is upset that by the City shoring up the sanitary sewer manhole in his front yard ditch, to prevent surface water from entering the system, has caused storm water to remain in his ditch. We will look at an inexpensive solution. Aside from this, any work would have to be funded via a special assessment district, which will not be popular.
- FIRE DEPARTMENT EVALUATION, CONTRACT RENEWAL, BUDGET** *(Status)*  
 I have begun meeting with Mr. Beatty. I will keep the Council posted.
- WWS INTERGOVERNMENTAL JURISDICTION SEWER ORDINANCE** *(Status)*  
 Pending. Mr. Delzer has completed an 'almost-final' draft. There are one or two items that need to be clarified and one or two changes to be made before it is ready. As stated, my opinion is that this ordinance is adequate and justified in regards to its intent and technical requirements. However, the City has no desire to enter into a "forever" agreement that blanket transmits all authority to the County for IPP issues and anything else related to sewer regulation, rates, fees, fines, etc. For the time being, they seem acceptable to this. Look to see an ordinance and resolution that designates the County as our enforcement agency very shortly.
- NON-MOTORIZED TRAIL SYSTEM, PHASE I** *(Status)*  
 Pending bid returns.

✓ **SR. CENTER, LEVY, BUILDING & FUTURE FUNDING PLAN (*Resolution*)**

As you recall, at the December 8<sup>th</sup> Meeting we endorsed a concept for an addition wherein the City would loan the SCASC funds that they were short for the construction of a 6,000+ SF addition. The Center would work the debt retirement and building upkeep, utilities and maintenance expenses into their budget. We have held a series of meetings with the Sr. Center and their architect regarding the planned addition and subsequent funding. The Center advises they are unable to make the numbers work and they request additional financial help from the City. Given the economic air and shrinking General Fund, we are unable to do this and in fact, we need relief from the expenses we now pay or at a minimum, they need to be capped. As a solution, the Center downsized the proposed addition, from 6,000+ SF to 4,616 SF, thus eliminating the need to borrow funds. In a proposal the Center made, they will fund the construction without borrowing from the City. Included with the project is a 2,880 SF basement that the City will fund. Cost estimates performed by the Architect Doug Stephens, for the entire project is \$879,863. Mr. Stephens apportions the City's cost for the basement and related ancillary expenses at \$338,430. I am in disagreement with the numbers as presented by Mr. Stephens. I recommend we bail on this project, find another solution to our storage problem and enter into a lease agreement with leasehold improvement options with the Sr. Center under the following general conditions:

1. The existing agreement(s) with the Center be dissolved.
2. As long as the County collects a levy in the City and distributes funds to the Sr. Center, the City will not levy for the authorized .5 mills for the duration of the collection period.
3. A new lease shall be drafted for the existing center.
4. Provisions within the new lease will allow for leaseholder improvements by the lessee (Sr. Center).
5. If the Sr. Center elects to construct an addition, the project will be theirs. The project will follow normal site plan approval process and in compliance with all applicable ordinances. All construction funding will be the responsibility of the Center.
6. The City will permit the expenditure of funds held by the Center for the construction of an addition to the existing building. If the Center fails to construct an addition, then the funds will be returned to the City and either refunded to the taxpayers or spent on programs or activities as provided for in the ballot language.
7. All expenses associated with the building and the Center will be the responsibility of the Center, including, but not limited to maintenance, utilities, janitorial, repairs, inspections, etc. The City will provide lawn care and snow removal, without charge. As long as the program is available, the City will designate the 15% allotment of C.D.B.G. Funds. Additionally, and as long as the City can afford it, an additional cash contribution of \$5,000 per year towards maintenance will be made. This contribution will terminate in the event the City is forced to reduce it's workforce due to budget constraints.
8. In the event of the dissolution of the SCASC, the building and all funds and assets will be turned over to the City.

On a final note, I have included a recent drawing that includes another structure added to the project, being a storage / garage to house a vehicle that the Center desires to

purchase. I have a resolution that endorses this concept included with tonight's agenda.

✓ **SPRINGBROOK, HERITAGE STREET-LIGHTING** (*Status*)

I am working on a recommendation and a policy in handling our condominium associations in an effort to treat them all the same. I will be back at a near future meeting for discussion and the adoption of a policy.

✓ **LABOR CONTRACTS & RETIREE HEALTHCARE** (*Status*)

Mr. Kehoe still needs a basic employment agreement and the Supervisor's contract has a wage re-opener. I will be back, probably at the next meeting with these.

On my contract, it probably needs revisiting for update purposes. I would like to take a pass on any rate increases for another year or two and until we are on better financial ground. I am not sure how the Council desires to handle an evaluation. As you recall, a couple of years ago I created a list of accomplishments and shortfalls as I saw them. I could bring the list up to date and then bring it back to the Council for discussion and review. Unless the Council has strong input one way or the other, I will do this and set it for a discussion item, hopefully soon. We can then go from here.

The POLC, AFSCME and the Supervisor Contracts will expire on June 30<sup>th</sup>. In review, I anticipate a 1% - 3% decrease in the levy collection this year. On our other revenues, I can only predict that they will also decline, maybe significantly. The first line of defense here in preserving the level of services that we can provide will most likely be a freeze on all contract wage increases for all employees, on a year-to-year basis.

✓ **MARATHON STATION BLIGHT & NON-CONFORMING USE** (*Status*)

There have been no new developments, applications, or correspondence on this property since the late December meeting with Mr. Klein, whom is acting as a real estate broker for the sale of the property. He has two potential purchasers, one doubtful and the other somewhat better. He also has looming foreclosure with the bank. He has negotiated a sale price that is lower than the loan amount and is under time constraints to get site plan approval, which the sale is contingent. Additionally, he is asking for the amount owed the City to be adjusted off, fearing that it may block the site plan approval, that will block the sale, that will lead to foreclosure, that will lead to a long term continued abandonment of the building...hmm. Mr. Klein attributes the problems to the site contamination and Marathon Oil's mishandling of the cleanup to MI-DEQ satisfaction. Some of the contamination issues I know to be true based on our dealings with the environmental engineer-monitoring firm (Inland Seas). I think the much bigger problem was the current owner purchased the property for a cost that greatly exceeded the market value, as it pertains to the highest and best use. Like so many other speculator's, they duped a bank into writing a shaky note, and here we all are. The environmental issues only aggravate the problem. At any rate, they need to make the February Planning Commission Meeting in order to keep the bank off their back. In order to do this, they have to have an accurate site plan in before January 15<sup>th</sup>. Mr. Klein was instructed that the adjustment of the debt owed the City would be a Council decision.

✓ **COUNTY E.M.S. ORDINANCE, AMBULANCE SERVICE** (*Status*)

Pending.

✓ **FEES, RATES & SERVICE CHARGES** (*Status*)

As you are aware, we have water rate increases now in effect and a sewer rate increase on the way. We can float for a bit using Fund Balance, but we will have to do something by next summer. As we have discussed in the past, the entire water rate system is in need of re-structuring. In short, it needs to go to a ready to serve charge with a per use charge. We will be back with some recommendations for new ordinances sometime this spring.

✓ **SALE OF CITY PROPERTY 5129 MORRISH ROAD** (*Status*)

Pending.

✓ **WWS, STORM WATER MANAGEMENT AGREEMENT** (*Status*)

We are still looking at this.

✓ **2009 MASTER PLAN & ZONING CODE REVIEW** (*Status*)

The City's Master Plan was last updated in 2004. Since these plans need to be revisited every five years or so, the City shall update the Master Plan sometime during the next calendar year. This can be quite a cumbersome process due to the requirements of State law; however, the impact of these plans is tremendous on all aspects of local governance. Since the last plan was adopted, there has not been significant change to the circumstances or assumptions that were used in the framing of that plan. As such, I expect a general review and acceptance will be in order, resulting in little substantial change to the 2004 Master Plan. We shall see. Expect this to show up in the form of a workshop in late spring or early summer. Additionally, the Planning Commission is having a public workshop to discuss updates to the Zoning Appendix A and zoning map. Expect some minor changes to the general provisions and the sign ordinance and some additional changes to the zoning map. There will eventually be an official public hearing and subsequent review by the City Council. Throughout this process, there may be some provisions of the Zoning Appendix A (concerning animals and parking) that shall be located with in the standard book of ordinances.

✓ **SWARTZ AMBULANCE AGREEMENT** (*Status*)

The contract/lease agreement that the City holds with Swartz Ambulance has expired and needs revisiting. There has been an idea or two proposed by staff to relocate the ambulance service to a more central location, perhaps on City property, in order to reduce the lease payments and upgrade the facilities. However, because of the need for Swartz to function closer to the urbanized area in order to make a Swartz Creek location feasible, it is not likely any such move shall occur. The status quo seems to be working for the time being so I expect a simple renewal to be in order. The holdup right now is due to the recent and untimely death of Mr. Harry Swartz, owner of Swartz Ambulance.

✓ **POLLING AGREEMENT, UNITED METHODIST CHURCH** (*Status*)

At the last meeting, we approved an agreement with the United Methodist Church to hold elections at the facility. The cost we approved was \$1,000 for use of the gymnasium and \$800 for the use of a smaller room referred to as the "Johnson Room". As a rule, we use the gymnasium for City Elections and the Schools use the Johnson Room for their elections. The original rent figures offered by the church were \$800 and \$600 for the day of the election only. They advised that we could probably have the facilities the afternoon before an election and the morning after, but could not necessarily guarantee it. When informed that we needed it reserved, they advised they would have to charge additional in order to hold it, henceforth the \$1,000 and \$800. In

a change of heart (after the last council meeting), the church advised they would honor the \$800 / \$600 price, inclusive of the before and after half days. At the request of the Mayor, we met with the Pastor and the Board Chair and settled on a further reduced cost of \$700 for use of the Gymnasium and \$350 for use of the Johnson Room. The agreement was executed at these numbers.

✓ **CAPITAL CONFERENCE** (*Status*)

The following Councilmembers are set for attendance at the Capital Conference: Binder, Hicks, Krueger & Abrams. If anyone needs anything, please get with me and we will take care of it.

✓ **NEIGHBORHOOD STABILIZATION PROGRAM** (*Discussion*)

Adam will be present at tonight's meeting to bring the Council up to date on the City's participation in this program.

## **NEW BUSINESS / PROJECTED ISSUES & PROJECTS**

✓ **GRANT OF EASEMENT, CONSUMER'S ENERGY** (*Resolution*)

The Raubinger Road Bridge Project, handled by the Road Commission, will require the relocation of a Consumer's Energy utility pole. Although the pole will not relocate out of the existing Consumer's right of way, it will cause the adjoining wires to hang over property owned by the City. An easement has been requested by Consumer's. Attached is a copy of the easement and a drawing. Recommend approval.

✓ **PARTICIPATE IN GENESEE COUNTY RE-CYCLING COALITION** (*Resolution*)

Included with tonight's agenda is an invoice for the continued participation in the Genesee County's Re-Cycling Coalition. The cost remains the same, as it has for many years now, \$750. I have a resolution for continued participation.

## **Council Questions, Inquiries, Requests and Comments**

- ❑ *C.S.O. Plaques, Lobby.* I am looking at options.
- ❑ *Mast Arm Traffic Lights, Street Sign Anchors (Silver vs. Black).* I have passed this along to our engineer who is checking into the replacement.
- ❑ *Public Safety Building Lot, Lighting.* Should be repaired. We will check it at various points throughout the evening hours to be certain.

**City of Swartz Creek**  
**RESOLUTIONS**  
**Regular Council Meeting, Monday February 23, 2009 7:00 P.M.**

**Resolution No. 090223-4A            MINUTES, FEBRUARY 9, 2009**

Motion by Councilmember: \_\_\_\_\_

**I Move** the Swartz Creek City Council hereby approve the Minutes of the Regular Council Meeting held February 9, 2009, to be circulated and placed on file.

Second by Councilmember: \_\_\_\_\_

Voting For: \_\_\_\_\_

Voting Against: \_\_\_\_\_

**Resolution No. 090223-5A            AGENDA APPROVAL**

Motion by Councilmember: \_\_\_\_\_

**I Move** the Swartz Creek City Council approve the Agenda as presented / printed / amended for the Regular Council Meeting of February 23, 2009 to be circulated and placed on file.

Second by Councilmember: \_\_\_\_\_

Voting For: \_\_\_\_\_

Voting Against: \_\_\_\_\_

**Resolution No. 090223-6A            CITY MANAGER’S REPORT**

Motion by Councilmember: \_\_\_\_\_

**I Move** the Swartz Creek City Council approve the City Manager’s Report of February 23, 2009, to be circulated and placed on file.

Second by Councilmember: \_\_\_\_\_

Voting For: \_\_\_\_\_

Voting Against: \_\_\_\_\_



Motion by Councilmember: \_\_\_\_\_

**I Move** the City of Swartz Creek grant an easement to Consumer's Energy, language as follows, drawing attached:

EASEMENT FOR ELECTRIC FACILITIES

321CIT -2007

58-36-400-007

File # 1845

*CITY OF SWARTZ CREEK, a Michigan municipal corporation, 8083 Civic Drive, Swartz Creek, Michigan 48473 , Grantor, for good and valuable consideration paid to Grantor by CONSUMERS ENERGY COMPANY, a Michigan corporation, One Energy Plaza, Jackson, Michigan 49201-2276, Grantee, receipt of which is hereby acknowledged, Conveys and Warrants to Grantee, its successors and assigns, Forever, the easement and right to enter upon the land hereinafter described and to construct, operate, maintain, repair, inspect, replace, improve, enlarge and remove electric transmission and distribution facilities consisting of one line of poles with wires, cables, conductors, braces, guys, anchors, transformers and other fixtures and appurtenances, and lateral lines where hereinafter indicated, in, over and across said land, including all public highways upon or adjacent to said land, which land is in the City of Swartz Creek, County of Genesee and State of Michigan, and described as:*

*A parcel of land in the Southeast 1/4 of Section 36, Township 7 North, Range 5 East described as: Beginning at the South 1/4 corner of Section 36; thence North 37 feet; thence Northeasterly along the South line of Supervisor's Plat of Larobardiere Acres to the West line of Lot 11 of said plat; thence South to the centerline of Swartz Creek; thence Southwesterly along said creek to the South line of Section 36; thence West to the place of beginning, and*

*That part of the North 1/2 of the Northeast 1/4 of Section 1, Township 6 North, Range 5 East lying Northerly of Swartz Creek.*

*Said line of poles is to be located in, over and across said land on a center line described as follows:*

*Beginning in the centerline of Consumers existing electric line at a point not more than 105 feet nor less than 55 feet North of the South line of Section 36, Township 7 North, Range 5 East at a point not more than 170 feet nor less than 120 feet East of the North and South 1/4 line of Section 36; thence Southwesterly to a point not more than 185 feet nor less than 135 feet South of the North line of Section 1, Township 6 North, Range 5 East at a point not more than 65 feet nor less than 51 feet West of the North and South 1/4 line of Section 1; thence Southwesterly to the centerline of Consumers existing electric line at a point not more than 380 feet nor less than 330 feet South of the North line of Section 1 at a point not more than 410 feet nor less than 360 feet West of the North and South 1/4 line of Section 1.*

*Also conveying the right, from time to time and at no additional cost to Grantee, to cut, trim, remove, destroy or otherwise control any trees and brush which may, in the opinion of the Grantee, interfere or threaten to interfere with or be hazardous to said facilities. Grantor agrees that no buildings or other structures will be placed under or over said facilities or within such proximity thereto as to interfere with or, in the opinion of Grantee, threaten to interfere with the construction, operation or maintenance of said facilities. Guy wires and anchors may be placed at such locations on and under the land described above as may be required. Additional wires, cables and conductors may be installed on said line of poles at any time hereafter. Nonuse or a limited use of this easement by Grantee shall not prevent Grantee from later making use of the easement to the full extent herein authorized.*

*This easement is exempt from real estate transfer tax pursuant to MCLA 207.505(f) and from State real estate transfer tax pursuant to the provisions of MCLA 207.526(f).*

*IN WITNESS WHEREOF, Grantor has caused this instrument to be executed by its duly authorized officers this \_\_\_\_\_ day of \_\_\_\_\_, 2009, pursuant to a Resolution of the City Commission dated the \_\_\_\_\_ day of \_\_\_\_\_, 2009.*

CITY OF SWARTZ CREEK

By \_\_\_\_\_  
Mayor

By \_\_\_\_\_  
Clerk

(MUNICIPAL CORPORATION ACKNOWLEDGMENT)

The foregoing instrument was acknowledged before me in \_\_\_\_\_ County, Michigan this \_\_\_\_\_ day of \_\_\_\_\_, 2009, by \_\_\_\_\_, Mayor, and \_\_\_\_\_, Clerk of the City of Swartz Creek, a Michigan municipal corporation on behalf of the corporation.

\_\_\_\_\_  
Notary public  
State of Michigan, County of \_\_\_\_\_  
Acting in the County of \_\_\_\_\_  
My commission expires \_\_\_\_\_

Prepared By: Nancy Todd 2/17/09  
Consumers Energy Company  
One Energy Plaza  
Jackson, Michigan 49201-2276

Return to: Consumers Energy Company  
Business Services – Real Estate  
Attn: NPTodd, EP7- 439  
One Energy Plaza  
Jackson, MI 49201-2276

Second by Councilmember: \_\_\_\_\_

Voting For: \_\_\_\_\_

Voting Against: \_\_\_\_\_

**Resolution No. 090223-8B**

**ANNUAL MEMBERSHIP CONTRIBUTION, GENESEE COUNTY RE-CYCLING COALITION**

Motion by Councilmember: \_\_\_\_\_

**I Move** the City of Swartz Creek continue its membership in the Genesee County Recycling Coalition and further, approve the annual membership payment of \$750 to the organization.

Second by Councilmember: \_\_\_\_\_

Voting For: \_\_\_\_\_

Voting Against: \_\_\_\_\_

Motion by Councilmember: \_\_\_\_\_

**WHEREAS**, the City passed a resolution on December 8, 2008 that endorsed a concept for the construction of an addition to the Sr. Center facility with the City loaning a portion of construction costs, the resolution as follows:

**Senior Center Addition, Construction Concept**

**Resolution No. 081208-04**

**(Carried)**

*Motion by Councilmember Hicks  
Second by Councilmember Hurt*

**WHEREAS**, the Swartz Creek Area Senior Citizens Center has been in operation since 1980 and incorporated since 1982 as a public not for profit IRS 501(c)(3) entity, serving a regional area defined as the Swartz Creek School District boundaries consisting of significant portions of four Townships; Gaines, Clayton, Mundy and Flint, and the Village's of Gaines, Lennon and City's of Swartz Creek and a small portion of Flint; and

**WHEREAS**, operational and activities funding through the 1980's and 1990's was primarily based on private donation revenues with City funded housing and associated expenses; and

**WHEREAS**, a signatory effort containing 697 validated voter signatures, asking for a ballot request of 0.5 mills for services, programs and operational costs, for a period of ten years, for the voters of the City of Swartz Creek, was presented to the City Council on August 14, 2000. The City Council voted to place the request before the voters at the General Election of November 7, 2000, the electorate of the City approving the request with the first collection in July, 2001; and

**WHEREAS**, in 2001, the Swartz Creek Area Senior Citizens determined the need and desire to expand or reconstruct their facilities due to continued and anticipated membership growth, and further, have drawn conceptual plans for additions to the existing building as well as reconstruction of a new building; and

**WHEREAS**, the City Levy of 0.5 mill was replaced with a county-wide 10 year levy of 0.7 mill on August 8, 2006, to provide programs, activities and services for seniors, to-which the operational activities for the Swartz Creek Area Senior Citizens Center is funded; and

**WHEREAS**, prior to the approval of the County millage, the Swartz Creek Area Senior Citizens Center, through the City's Levy and private donations, set aside approximately \$300,000 to fund either a capital improvement project for the existing building or the construction of a new facility; and

**WHEREAS**, the cost of a new building was determined to be prohibitive and although an addition may present some logistical problems, it is the only cost feasible solution; and

**WHEREAS**, the Senior Center has retained the services of an architect and drafted two conceptual floor plans and preliminary cost estimates for an addition, copies of which are attached; and

**WHEREAS**, Genesee County Metropolitan Planning Commission, the medium through which the County Senior Levy funds are distributed, have indicated that the Swartz Creek Area Senior Citizens Center is eligible for a \$200,000 grant for capital improvements in the form of an addition to the existing Center, such grant would bring a total of \$500,000 the Senior Center has to spend towards an expansion to the Center; and

**WHEREAS**, the Swartz Creek Senior Citizens Center has requested permission to construct an addition and assistance from the City in funding the balance of construction, estimated to be between \$300,000 and \$500,000; and

**WHEREAS**, the City is unable to make a contribution for such an amount from its General Fund, however, under certain conditions, a loan is possible from an enterprise fund such as water or sewer.

**NOW, THEREFORE, BE IT RESOLVED** that the City Council endorse the selection of Option Number A, as an addition to the Swartz Creek Senior Center Building, and further, directs the Administrative Staff to work with the Swartz Creek Area Senior Citizens Center Board, as follows:

1. In conjunction with the Swartz Creek Area Senior Citizens Center, initiate formal application to Genesee County for a grant in the maximum amount allowable.
2. Prepare a draft lease between the City and the Swartz Creek Senior Citizens Center.

3. Prepare a draft loan agreement between the General Fund and an appropriate enterprise fund.
4. Prepare a construction budget.
5. Prepare a revised draft of the Senior Citizens Center Budget.
6. Initiate site plan review process.

**BE IT FURTHER RESOLVED**, that upon completion of each of the directives and any other data that may be needed, that they be brought back before the City Council for review, and further, upon collection of all data, information and commitments, a final decision by the City shall be rendered.

**BE IT FURTHER RESOLVED**, that the City Council hereby finds and determines that the making of the proposed building improvements for the use of the Swartz Creek Area Senior Citizens, Inc. constitutes actions directed toward the improvement of the social, legal, health, housing, educational, emotional, nutritional, recreational, or mobility status of older persons within the purview of 1976 PA 39 [MCL 400.571 et seq].

Discussion Took Place.

YES: Krueger, Porath, Shumaker, Abrams, Binder, Hicks, Hurt.  
NO: None. Motion Declared Carried.

**WHEREAS**, the Swartz Creek Area Senior Citizens Center has determined that the costs for the planned addition exceed the financial capabilities of the organization and without significant financial assistance from the City, they may be limited in their mission of providing programs and activities for Senior's; and

**WHEREAS**, the City, although desirous to assist, is facing significant financial challenges in the upcoming years and cannot commit to additional General Fund expenses in any department, and further, will need to reduce its current contributions in all General Fund supported departments in order to continue to provide adequate levels of service to its residents; and

**WHEREAS**, the Sr. Center has downsized the proposed addition and has drafted a conceptual budget that is economical and affordable and permits them to construct an addition that will eliminate the need to borrow funds from the City; and

**WHEREAS**, the City Council hereby finds and determines that the making of the proposed downsized building improvements for the use of the Swartz Creek Area Senior Citizens, Inc. constitutes actions directed toward the improvement of the social, legal, health, housing, educational, emotional, nutritional, recreational, or mobility status of older persons within the purview of 1976 PA 39 [MCL 400.571 et seq].

**NOW, THEREFORE**, I move that the City Council direct the City Manager, City Attorney and staff to prepare a lease agreement with the following general conditions:

1. The existing agreement(s) with the Center be dissolved.
2. As long as the County collects a levy within the City and distributes funds to the Sr. Center, the City will not levy for the authorized .5 mills for the duration of the collection period.
3. A new lease shall be drafted for the existing center.
4. Provisions within the new lease will allow for leaseholder improvements by the lessee (Sr. Center).

5. If the Sr. Center elects to construct an addition, the project will be theirs. The project will follow normal site plan approval process and in compliance with all applicable ordinances. All construction funding will be the responsibility of the Center.
6. The City will permit the expenditure of funds held by the Center for the construction of an addition to the existing building. If the Center fails to construct an addition, then the funds will be returned to the City and either refunded to the taxpayers or expended on programs or activities as provided for in the ballot language.
7. All expenses associated with the building and the Center will be the responsibility of the Center, including, but not limited to maintenance, utilities, janitorial, repairs, inspections, etc. The City will provide lawn care and snow removal, without charge. As long as the program is available, the City will designate the 15% allotment of C.D.B.G. Funds. Additionally, and as long as the City can afford it, an additional cash contribution of \$5,000 per year towards maintenance will be made. This contribution will terminate in the event the City is forced to reduce its workforce due to budget constraints.
8. In the event of the dissolution of the SCASC, the building and all funds and assets will be turned over to the City.

**BE IT FURTHER DIRECTED** that upon negotiation and tentative agreement with the Sr. Center, a final draft be brought back before the Council for review and determination.

Second by Councilmember: \_\_\_\_\_

Voting For: \_\_\_\_\_

Voting Against: \_\_\_\_\_

***City of Swartz Creek***  
**Regular Council Meeting Minutes**  
*Of the Meeting Held*  
**Monday February 9, 2009 7:00 P.M.**

**CITY OF SWARTZ CREEK**  
**SWARTZ CREEK, MICHIGAN**  
**MINUTES OF THE COUNCIL MEETING**  
**DATE 02/09/2009**

The meeting was called to order at 7:00 p.m. by Mayor Abrams in the Swartz Creek City Council Chambers, 8083 Civic Drive.

Invocation and Pledge of Allegiance to the Flag.

Councilmembers Present: Abrams, Binder, Hicks, Hurt, Krueger, Porath, Shumaker.

Councilmembers Absent: None.

Staff Present: City Manager Paul Bueche, Assistant City Manager Adam Zettel, Deputy City Clerk/Finance Officer Mary Jo Clark, City Attorney Richard Figura.

Others Present: Tommy Butler, Bob Plumb, Boots Abrams, Steve Shumaker.

Mayor Abrams introduced Commissioner Pat Lockwood who made a brief presentation about the County's Neighborhood Revitalization Program, which is a federally funded program to help communities with foreclosed houses. Ms. Lockwood stated that the planning department at the County must be contacted by Friday, February 13, 2009 if communities are interested in the program.

Discussion Took Place.

**APPROVAL OF MINUTES**

**Resolution No. 090209-01**

**(Carried)**

Motion by Mayor Pro-Tem Porath  
Second by Councilmember Hurt

**I Move** the Swartz Creek City Council hereby approve the Minutes for the Regular Council Meeting, held January 26, 2009, as amended, to be circulated and placed on file.

YES: Binder, Hicks, Hurt, Krueger, Porath, Shumaker, Abrams.

NO: None. Motion Declared Carried.

## **APPROVAL OF AGENDA**

### **Resolution No. 090209-02**

**(Carried)**

Motion by Councilmember Krueger  
Second by Councilmember Shumaker

**I Move** the Swartz Creek City Council approve the Agenda, as printed, for the Regular Council Meeting of February 9, 2009 to be circulated and placed on file.

YES: Hicks, Hurt, Krueger, Porath, Shumaker, Abrams, Binder.  
NO: None. Motion declared carried.

## **REPORTS AND COMMUNICATIONS:**

### **City Manager's Report**

#### **Resolution No. 090209-03**

**(Carried)**

Motion by Councilmember Shumaker  
Second by Councilmember Hurt

**I Move** the Swartz Creek City Council approve the City Manager's Report of February 9, 2009, to be circulated and placed on file.

Discussion Took Place.

YES: Hurt, Krueger, Porath, Shumaker, Abrams, Binder, Hicks.  
NO: None. Motion declared carried.

All other reports and communications were accepted and placed on file.

## **MEETING OPENED TO THE PUBLIC:**

Boots Abrams talked about the lights being dim in the parking lot of the fire station.

Councilmember Shumaker made a presentation to Rowe Engineering from the Veteran's Memorial Committee to thank them for all of their help and work that they donated to the Memorial.

Jim Florence, 4296 Springbrook, on behalf of the Senior Center, thanked the Mayor for his years of service to the Swartz Creek Area Senior Center.

## **COUNCIL BUSINESS:**

**Updates: Stimulus, NSP, Morrish Property, CDBG Project, Appraisals**

## Discussion Topic

Assistant City Manager Zettel gave a brief presentation on the Neighborhood Stabilization Program and the Economic Stimulus Package

Mr. Zettel also spoke about the City owned property located at 5189 Morrish Road. He stated that it would take about \$15,000 to \$20,000 to make the property ready to be rented out and he feels it may make more sense to demolish it.

Mr. Zettel talked about the commercial appraisals that Landmark Appraisals did for the City.

### **CDBG Elms Road Enhancement Project**

**Resolution No. 090209-04**

**(Carried)**

Motion by Councilmember Hicks  
Second by Councilmember Hurt

**WHEREAS**, the City of Swartz Creek, on July 14, 2008, amended the three year Community Development Block Grant Distribution in the total amount of \$37,672, and authorized these funds to be allocated as follows: 15% to the Swartz Creek Senior Citizens Operations in the amount of \$5,650.08, and the remaining 85% to the Elms Road Enhancement Project in the amount of \$32,021.02; and

**WHEREAS**, the Elms Road Enhancement Project consists of lighting, landscaping, and other streetscape amenities; and

**WHEREAS**, all CDBG projects must be approved by the GCMPC to be bid in accordance with federal statute; and

**WHEREAS**, Consumers Energy is, by contract, the sole provider of public lighting services on city streets and is solely responsible for all installation of new lines and lights and is therefore exempt from the bidding process; and

**WHEREAS**, a price quotation for the lighting portion of the Project, as designed by the City's engineer has been received in the amount of \$21,237.23.

**NOW, THEREFORE**, the City of Swartz Creek hereby approves the lighting portion of the Project as designed and quoted for immediate construction and directs staff to seek bids on the remaining portion of the Project.

Discussion Took Place.

YES: Krueger, Porath, Shumaker, Abrams, Binder, Hicks, Hurt.  
NO: None. Motion Declared Carried.

### **2010 Application T.I.P. Projects**



**Resolution No. 090209-05**

**(Carried as Amended)**

Motion by Councilmember Binder  
Second by Councilmember Hurt

**WHEREAS**, the City of Swartz Creek is a local government unit eligible to receive funding under the Transportation Improvement Program; and,

**WHEREAS**, the City of Swartz Creek, through working with its consultants, administrative staff and the Genesee County Metropolitan Planning Commission's Transportation Section, have identified the need to repair or improve the following Federal Aid Eligible Major Streets:

1. Miller Road from Elms Road to Tallmadge Court
2. Miller Road from Elms Road to Seymour
3. Bristol Road from the General Motors SPO Plant to Miller Road
4. Trail project from Heritage Subdivision to Elms Park

**WHEREAS**, the Swartz Creek City Council has considered the making of such repairs and improvements in open session following the hearing of comments on the need for the improvements from the city's engineer and administrative staff;.

**NOW THEREFORE BE IT RESOLVED**, the City of Swartz Creek hereby approves and submits the following applications for street repair for 2010-2013 Genesee County Transportation Improvement Projects (T.I.P.) funding:

1. Miller Road from Elms Road to Tallmadge Court
2. Miller Road from Elms Road to Seymour
3. Bristol Road from the General Motors SPO Plant to Miller Road
4. Trail project from Heritage Subdivision to Elms Park

**Amendment to Resolution No. 090209-05**

Motion by Councilmember Hurt  
Second by Mayor Pro-Tem Porath

**I Move** that the Swartz Creek City Council add the following street to the list for T.I.P funding:

5. Miller Road from Tallmadge Court to Dye Road.

YES: Porath, Shumaker, Abrams, Binder, Hicks, Hurt, Krueger.  
NO: None. Motion Declared Carried.

Discussion Ensued.

Vote on Original Resolution as Amended

YES: Shumaker, Abrams, Binder, Hicks, Hurt, Krueger, Porath.

NO: None. Motion Declared Carried.

**Elms Road Project County Road Commission Agreement, Match Funding Split**

**Resolution No. 090209-06**

**(Carried)**

Motion by Councilmember Hurt  
Second by Councilmember Hicks

**WHEREAS**, the City applied for and received Federal Aid Funding for the reconstruction and repair of Elms Road between I-69 and the north City Limit; and

**WHEREAS**, the project was designed, bid, awarded and constructed in the summer of 2008; and

**WHEREAS**, a 1,300' section of the project is a border road that divides the City from the Township, the road jurisdiction under the control of the Genesee County Road Commission; and

**WHEREAS**, the City's staff has negotiated with the County Road Commission and reached an agreement that provides for a 50-50 split of the match portion of the cost of the 1,300' section of the border road, the total cost being \$48,963, the City and the County's share being \$24,481.53 each.

**NOW, THEREFORE, I MOVE** the City of Swartz Creek enter into a letter of understanding with the Genesee County Road Commission to split the match portion of the 1,300' border section of the Elms Road Project, in accordance with the cost projections attached hereto, and further, prepare and send an invoice in the amount of \$24,481.53, funds to be returned to 202 major Streets.

Discussion Took Place.

YES: Abrams, Binder, Hicks, Hurt, Krueger, Porath, Shumaker.

NO: None. Motion Declared Carried.

**Polling Agreement, United Methodist Church**

**Resolution No. 090209-07**

**(Carried)**

Motion by Mayor Pro-Tem Porath  
Second by Councilmember Hurt

**I Move** the City of Swartz Creek approve the location of the City's polling place, inclusive of precincts one, two, three and four, at the United Methodist Church, 7400 Miller Road, and further, direct the Mayor and City Clerk to execute an agreement on behalf of the City that sets forth terms and conditions for the use of the facilities, as follows:

## **POLLING PLACE AGREEMENT**

### **CITY OF SWARTZ CREEK And UNITED METHODIST CHURCH**

---

This agreement is made this 9<sup>th</sup> day of February, 2009 by and between the City of Swartz Creek, a Michigan Municipal Corporation, with principal offices at 8083 Civic Drive, Swartz Creek, Michigan 48473 (“City”) and the United Methodist Church of Swartz Creek, an Ecclesiastical Corporation, with principal offices at 7400 Miller Road, PO Box 268, Swartz Creek, MI 48473 (“Church” or “Owner”)

**WHEREAS**, the City is in need of a conveniently located facility with sufficient size to serve as a polling place for various elections conducted by the City; and

**WHEREAS**, the Owner has a building located at 7400 Miller Road, Swartz Creek, MI 48473 which building has sufficient space for the efficient conduct of elections;

**NOW, THEREFORE, the City and the Owner, acting by and through their duly authorized representatives, hereby AGREE AS FOLLOWS:**

1. The owner will make available to the City sufficient space in its building located at 7400 Miller Road, Swartz Creek, MI 48473 (the “Facility”) for the City to establish a polling place and to conduct City and school elections therein.
2. The space provided within the Facility shall be sufficient to accommodate voters as well as house the election workers and election equipment necessary to conduct a City election and/or a school election. To that end, school elections held on dates other than those on which a City election is held may be held in the so called “Johnson Room” which is located in the northern most room in the newest building addition, with general elections being held in the gym which is significantly larger.
3. The elections for which the City will use the Facility are:

- a) The February regular election held on the fourth Tuesday in February;
  - b) The May regular election held on the first Tuesday after the first Monday in May;
  - c) The August regular election held on the first Tuesday after the first Monday in August;
  - d) The November regular election held on the first Tuesday after the first Monday in November; and
  - e) Other dates for special elections held in accordance with the Michigan Election law.
4. For each said election, the Owner shall make the space in the Facility available to the City one-half ( $\frac{1}{2}$ ) day before the scheduled election date and no later than 1:00 PM, and for no more than one-half ( $\frac{1}{2}$ ) day after each scheduled election date, up to 11:00 AM. Said dates will be extended whenever reasonably possible if such extension is necessary due to a change in the standard election procedures. Additional fees for such an extension may be decided by the parties. The City will need to have access to the facility by 6:00 A.M. of an election day. It is anticipated that the City personnel will vacate the facility by 10:00 P.M. of an election day. Table and chair set-up arrangements will be provided for by the Church, upon advance submittal of a diagram.
  5. The City shall pay the Owner the sum of Seven-Hundred & Fifty Dollars (\$750) for each time the City uses the Johnson Room for an election and One-Thousand Dollars (\$1,000) for each time the City uses the gym for an election.
  6. The term of this agreement extends until December 31, 2013, however, either party may terminate this agreement for any reason upon giving the other party One Hundred Eighty (180) days written notice of such termination. In the event the Church elects to terminate this agreement, notice of such shall be sent to the City Clerk by certified-registered mail, return receipt requested.
  7. The Owner shall take all reasonable steps to ensure that the Facility is maintained in such a condition that election workers and voters will be able to conduct their activities at the Facility in a safe manner. If additional snow removal services are needed, other than that which may be provided by the Church, the City of Swartz Creek reserves the right to remove snow from any parking lot or sidewalk that may be

needed to conduct election services. The removal of snow shall be without cost to the Church.

8. The City shall take all reasonable steps to ensure that its election workers do not create any nuisance at the Facility or create any condition which would present a danger to persons using the Facility.
9. Each party will indemnify and hold the other party harmless for any damages to persons or property occasioned by, and to the extent of, its negligence.
10. The Church shall maintain a general liability insurance policy covering injuries to persons and property for persons using its Facility in an amount acceptable from time to time to the City Manager, but in no event less than One-Million Dollars (\$1,000,000) per occurrence and Two-Million Dollars Aggregate, and shall list the City as an additional insured on said policy.
11. The City shall maintain a general liability insurance policy covering injuries to persons property for persons using the Facility for activities in connection with a City election. Such insurance shall be in an amount no less than One-Million Dollars (\$1,000,000) per occurrence and Two-Million Dollars Aggregate, and shall list the Owner as an additional insured on said insurance policy.
12. The Owner shall maintain a policy of fire and casualty insurance on the Facility and such insurance coverage shall cover any equipment and other property of the City while such equipment and property is at the Facility for the purposes of this agreement.
13. The City shall provide casualty and property damage insurance coverage for its equipment and other property placed on the premises of the facility for the purposes of this agreement.
14. Except as stated in Section 6, any notices required to be given by either party to this agreement to the other shall be sufficient if given in writing and deposited in a United States Postal Service mailbox with sufficient first class postage thereon and addressed to:

a. For the City:

Clerk, City of Swartz Creek  
City Manager, City of Swartz Creek

8083 Civic Drive,  
Swartz Creek, Michigan 48473

With a copy to:

Richard J. Figura, Esq.  
SIMEN, FIGURA & PARKER, P.L.C.  
5206 Gateway Centre Blvd, Ste. 200  
Flint, MI 48507

b. For the Owner:

Rev. Dr. J. D. Landis  
Pastor  
United Methodist Church of Swartz Creek  
7400 Miller Road  
PO Box 268  
Swartz Creek, MI 48473

15. This is the entire agreement between the parties regarding the City's use of the Facility for staging a polling place for elections and no other agreement regarding same is valid or enforceable unless such agreement is in writing as an amendment hereto.

***(Signature Page to Follow)***

**CITY OF SWARTZ CREEK**

**UNITED METHODIST CHURCH  
OF SWARTZ CREEK**

\_\_\_\_\_  
**Richard B. Abrams**, Mayor  
Board

\_\_\_\_\_  
**Ivan Brouwer**, Chairman-

\_\_\_\_\_  
**Juanita Aguilar**, City Clerk  
Pastor

\_\_\_\_\_  
**Rev. John D. Landis**,

approved as to form:  
Richard J. Figura, City Attorney  
Feb 9, 2009

Discussion Ensued.

YES: Binder, Hicks, Hurt, Krueger, Porath, Shumaker, Abrams.  
NO: None. Motion Declared Carried.

**C.D.B.G. Designation of Authorization**

**Resolution No. 090209-08**

**(Carried)**

Motion by Councilmember Krueger  
Second by Councilmember Hurt

**WHEREAS**, the City of Swartz Creek participates in the Genesee County Community Development Program; and

**WHEREAS**, the Genesee County Community Development Program has requested that we update our authorized card.

**NOW, THEREFORE, BE IT RESOLVED** that the following individuals be authorized to request reimbursement from the Community Development Block Grant Program:

1. Juanita Aguilar, City Clerk
2. Mary Jo Clark, Finance Director
3. Adam Zettel, Local Program Coordinator, Zoning Administrator, Assistant City Manager

Discussion Ensued.

YES: Hicks, Hurt, Krueger, Porath, Shumaker, Abrams, Binder.

NO: None. Motion Declared Carried.

### **Appropriation, Commercial & Industrial Property Re-Appraisal**

**Resolution No. 090209-09**

**(Carried)**

Motion by Councilmember Shumaker  
Second by Councilmember Hurt

**I Move** the City of Swartz Creek appropriate an amount not to exceed \$4,250 to the City's contract assessor, LandMark Appraisal, final payment installment for the re-appraisal of all Commercial and Industrial Properties.

Discussion Took Place.

YES: Hurt, Krueger, Porath, Shumaker, Abrams, Binder, Hicks.

NO: None. Motion Declared Carried.

### **MEETING OPENED TO THE PUBLIC**

City Attorney Dick Figura reminded the Council that if they send e-mail messages back and forth to each other, the communication should be on a one to one basis and that when they reply to a message, reply only to that person and not to all as it would violate the open meetings act.

### **REMARKS BY COUNCILMEMBERS:**

Councilmember Krueger commended Mayor Abrams on his recognition of the potential conflict of interest with the Senior Center and his decision to step down from his position on the Senior Center Board in order to avoid a possible conflict. Mr. Krueger also stated that he liked the article that Laura Angus wrote about the Mayor and his wife.

Councilmember Shumaker agreed with Mr. Krueger about the article by Laura Angus.

Councilmember Hurt also liked the article. Mr. Hurt stated that he was impressed with an article that he read in the Swartz Creek News about the program that Clayton Township has for looking in on seniors. Mr. Hurt stated that he was impressed by the leadership shown by Clayton Township and said that he would like to see something similar in Swartz Creek.

Mayor Abrams talked about the MML seminar on April 3, 2009 in Wayne County. Mr. Abrams spoke about being a judge for the 4<sup>th</sup> and 5<sup>th</sup> graders at the Syring Elementary spelling bee. Mr. Abrams stated that the finals for the local schools will be in the Swartz Creek Council Chambers on Tuesday, February 24, 2009.

**ADJOURNMENT:**

There being no objection, Mayor Abrams declared the meeting adjourned at 8:25 p.m.

Richard Abrams, Mayor

Mary Jo Clark, Deputy City Clerk



DATE: FEBRUARY 16, 2009  
TIME: 7:00 PM  
LOCATION: STATION 1  
SUBJECT: SWARTZ CREEK AREA FIREBOARD AGENDA



- I. CALL TO ORDER  
A. PLEDGE OF ALLEGIANCE  
B. ROLL CALL  
C. ADDITIONS/CHANGES/DELETIONS AND AGENDA APPROVAL:  
D. SPECIAL PRESENTATIONS/ANNOUNCEMENTS:
- II. APPROVAL OF MINUTES  
A. JANUARY 19, 2008 MEETING:
- III. CORRESPONDENCE:  
A. JANUARY INCIDENT SUMMARY REPORT:
- IV. PROFESSIONAL SERVICE REPORTS:  
A. JANUARY FINANCIAL REPORT:  
  
B. JANUARY BILLS LIST:
- V. COMMITTEE REPORTS:  
A. BY-LAWS COMMITTEE - Chairman Rick Clolinger, Boots Abrams, Richard Derby, Bill Cavanaugh and Brent Cole:  
1. Equipment disposal  
  
B. HEALTH AND SAFETY COMMITTEE: Chairman Greg Childers (Members Chief Cole, Assistant Chief Merriam, Captain Tabit, Lieut. Jones & FF VanArsdale)  
  
C. FIRE CHIEF PERFORMANCE EVALUATION: (Chairman Ray Thornton, Richard Derby and David Hurt)
- VI. OLD BUSINESS:  
A. APPARATUS UPDATE from Battalion Chief Jack King-  
1. Monthly apparatus status report attached  
  
B. FEMA GRANT STATUS: The total invoice amount from Douglass Safety for the FEMA grant is \$126,617.20. 95% of this amount, in whole numbers is \$120,287.00, which was requested from FEMA on February 5, 2009. The municipal 5% matching funds equals \$6,331.00. Out of the \$7,070.00 provided by the municipalities, \$739.00 (\$369.50 each) will be refunded. Checks will be issued (February 17) to Douglass Safety and the municipalities to complete the transaction.  
Records are being kept for future FEMA audits.

C. 2008 FUND BALANCE REIMBURSEMENT: Report from Elected Representatives

VII. NEW BUSINESS:

- A. NEW MEMBERS FOR PLACEMENT ON PROBATION: none
- B. MEMBERS ELIGIBLE TO COME OFF PROBATION: none
- C. MEMBERS RESIGNING/TERMINATING: none
- D. MEMBERS ELIGIBLE FOR REINSTATEMENT: none

E.

F.

G.

VIII. GENERAL INFORMATION:

- A. MUNICIPAL BILLINGS for January.
- B. The flower fund balance is currently \$30.00.
- C.

IX. OPEN TO THE PUBLIC:

X. COMMENTS OF FIRE DEPARTMENT PERSONNEL (THROUGH THE CHIEF AND/OR HIS DESIGNATE:

XI. CHAIN OF COMMAND APPEAL TO THE FIREBOARD:

XII. COMMENTS FROM FIREBOARD MEMBERS:

XIII. MEETING ADJOURNMENT:

# REGULAR MEETING

JANUARY 19, 2009

## SWARTZ CREEK AREA FIRE DEPARTMENT

The regular meeting of the Swartz Creek Area Fire Board was held at Station #2, January 19, 2009. Chairman, Mike Messer, called the meeting to order at 7:00p.m.

### I. CALL TO ORDER:

- A. PLEDGE OF ALLEGIANCE
- B. ROLL CALL

#### Board Members Present:

- Chairman, Mike Messer
- Secretary/Treasurer, Boots Abrams
- Clayton Representative, Richard Derby
- Clayton Representative, Greg Childers
- City Representative, Ray Thornton
- City Representative, Dave Hurt

#### Board Members Absent:

- City Representative, Rick Clolinger

#### Staff Present:

- Fire Chief, Brent Cole
- Asst. Chief, Eric Merriam
- Acct./Clerical, Kim Borse
- Attorney, Bill Cavanaugh

#### Staff Absent:

#### Others Present:

- Jack King, Batt. Chief
- Steve Tabit, Captain
- Karen Merriam, Firefighter
- Anthony Davis, Firefighter
- Bryan Wistuba, Firefighter
- Jeff Kelley, Firefighter
- Bob Plumb, Firefighter

C. AGENDA: ADDITIONS/CHANGES/DELETIONS/APPROVAL:NONE

### II. APPROVAL OF MINUTES

#### A. DECEMBER 15, 2008 BOARD MEETING

- **Resolution 011909-01**  
Motion by Dave Hurt  
Second by Boots Abrams

The SCAFD Board does hereby approve the minutes of the December 15, 2008 board meeting, as presented.

YES: Abrams, Childers, Derby, Hurt, Thornton, Messer

NO: None Motion declared carried

### III. CORRESPONDENCE:

#### A. DECEMBER INCIDENT SUMMARY REPORT:

- **Resolution 011909-02**  
Motion by Dave Hurt  
Second by Rick Derby

The SCAFD Board does hereby accept the December 2008 Incident Summary, as presented

YES: Abrams, Childers, Derby, Hurt, Thornton, Messer

NO: None Motion declared carried

### IV. PROFESSIONAL SERVICE REPORTS:

#### A. DECEMBER FINANCIAL STATEMENT:

- **Resolution 011909-03**  
Motion by Boots Abrams  
Second by Dave Hurt

The SCAFD Board does hereby approve the December 2008 line item transfers and resulting financial statement, as presented

YES: Abrams, Childers, Derby, Hurt, Thornton, Messer

NO: None Motion declared carried

B. DECEMBER BILLS LIST:

• Resolution 011909-04

Motion by Rick Derby

Second by Ray Thornton

The SCAFD Board does hereby approve the December 2008 bills list, as presented.

YES: Abrams, Childers, Derby, Hurt, Thornton, Messer

NO: None Motion declared carried

**V. COMMITTEE REPORTS:**

- A. BY-LAWS COMMITTEE MEETING: NONE
- B. HEALTH & SAFETY COMMITTEE: NONE
- C. FIRE CHIEF PERFORMANCE EVALUATION: NONE

**VI. OLD BUSINESS**

- A. APPARATUS UPDATE:
  - 1. Monthly report from Batt. Chief King
- B. FEMA GRANT STATUS:

**VII. NEW BUSINESS**

- A. NEW MEMBER(S) TO BE PLACED ON PROBATION: NONE
- B. MEMBER TO COME OFF PROBATION: NONE
- C. MEMBERS RESIGNING/TERMINATING: NONE
- D. MEMBERS ELIGIBLE FOR REINSTATEMENT: None
- E. 2008 FUND BALANCE REIMBURSEMENT: Chief Cole requested the Board to discuss with the Municipalities alternatives for the fund balance to be designated for Fire Department use.

**VIII. GENERAL INFORMATION**

- A. MUNICIPAL BILLINGS
- B. FLOWER FUND IS CURRENTLY \$30.00
- C. 2008 ALARM BREAKDOWN
- D. 1999-2008 STATISTICS
- E. SCAFD ORGANIZATIONAL CHART
- F. 2008 INVENTORY

**IX. OPEN TO THE PUBLIC: NONE**

**X. COMMENTS OF FIRE DEPARTMENT PERSONNEL, THROUGH THE CHIEF: NONE**

**XI. CHAIN OF COMMAND APPEAL TO THE FIRE BOARD: NONE**

**XII. COMMENTS OF THE FIREBOARD:**

- Childers: Happy New Year  
Apologized for missing Dec. meeting-forgot about time change
- Derby: None
- Abrams: Glad to see B. Plumb back to active duty
- Hurt: None
- Thornton: None
- Messer: Happy New Year  
Welcome back to B. Plumb

**XIII. ADJOURNMENT OF MEETING:**

Meeting adjourned at 7:45 p.m.

The next regular meeting will be 02/16/09 at Station 1 at 7:00 pm

MIKE MESSER  
CHAIRMAN  
SWARTZ CREEK AREA FIRE BOARD

KIM BORSE  
ACCOUNTING/CLERICAL SPECIALIST  
SWARTZ CREEK AREA FIRE DEPT.

SWARTZ CREEK AREA FIRE DEPT, SWARTZ CREEK MICHIGAN 48473

Incident Log for 01/01/2009 through 01/31/2009

Printed: 02/05/2009

Inc. No. - Exp. Location	Date	Disp. Time	Sta. Incident Type	Owner Name	No. Resp Prop. Loss	Disp. to Enrte. Min.	Resp. Min. Cont. Loss	Officer in Charge	Total Hr:Min:Sec
0000001-000 5331 Reuben ST	01/04/2009	17:30	12 571 Standby during Mut Aid		28 \$ 0	0.00 \$ 0	19.00		1:44:00
0000002-000 2487 N Elms RD	01/05/2009	11:42	2 611 Lift assist, cancelled		10 \$ 0	0.00 \$ 0	1.00	MERRIAM, ERIC M - ASSISTANT	0:08:00
0000003-000 7119 Rosewood DR MRS Sophie Lajewski	01/07/2009	10:35	2 311 Lift assist, assist EMS crew	MRS Sophie Lajewski	11 \$ 0	0.00 \$ 0	19.00	Tesner, Richard R - LIEUTENANT	0:55:00
0000004-000 10026 W Coldwater RD	01/07/2009	12:18	12 111 Strtr Fire; AMA to Flushing		19 \$ 0	0.00 \$ 0	17.00		4:42:00
0000005-000 8450 Maurice LN MS Holly Skiver	01/10/2009	20:06	12 611 AMA to Flushing; cancelled		19 \$ 0	0.00 \$ 0	0.00		0:15:00
0000006-000 7296 104th ST	01/15/2009	13:20	12 611 AMA to Flushing, cancelled		21 \$ 0	0.00 \$ 0	0.00		0:10:00
0000007-000 9160 Luea LN MS Patricia Azelton	01/16/2009	09:00	1 733 Smoke detector activation due to	MS Patricia Azelton	22 \$ 0	0.00 \$ 0	10.00	COLE, BRENT D - CHIEF	0:39:00
0000008-000 8150 W GRAND BLANC RD	01/21/2009	21:45	12 111 AMA to Gaines Twp		22 \$ 0	0.00 \$ 0	11.00		3:15:00
0000009-000 4948 Schafer DR MS Linda Tomlin	01/23/2009	07:40	1 111 Carpet fire from O2 usage	MS Roxanne Valentine	18 \$ 200	0.00 \$ 200	9.00	KING, JACK L - BATT CHIEF	1:00:00
0000010-000 7111 N Nichols RD	01/23/2009	20:46	12 111 Structure; AMA to Flushing		24 \$ 0	0.00 \$ 0	19.00	MERRIAM, ERIC M - ASSISTANT	3:34:00
0000011-000 7345 W baldwin RD	01/26/2009	11:11	12 611 AMA to Gaines; cancelled		14 \$ 0	8.00 \$ 0	0.00		0:31:00
0000012-000 8156 Kings Row LN	01/27/2009	19:48	12 611 AMA to Flushing; cancelled		19 \$ 0	0.00 \$ 0	11.00		0:17:00
0000013-000 1160 S Elms RD MS Madeline Duhart	01/30/2009	20:08	2 357 Extrication of victim(s) from		16 \$ 0	0.00 \$ 0	7.00	COLE, BRENT D - CHIEF	0:40:00

Incidents by Shift Including Exposures

	No. Resp.	Total Hr:Min	Prop. Loss	Cont. Loss	0	1	2	3	4
Totals:	243	17:50:00	\$ 200	\$ 200	0	6	6	1	0

29

The total number of incidents, including exposure fires is 13.

The number of exposure fires is 0.

3

SWARTZ CREEK AREA FIRE DEPARTMENT  
Income/Expense Report  
For the One Month Ending January 31, 2009

	Description	Current Mth	Y-T-D	Budget	Remain.Budget	% Budget
<b>Revenues</b>						
3582	OPERATING CONTRIBU	111,850.00	111,850.00	251,860.00	140,010.00	(0.44)
3583	EQUIPMENT CONTRIBU	0.00	0.00	45,840.00	45,840.00	0.00
3628	MISC. INCOME (SUNDR	0.00	0.00	0.00	0.00	0.00
3664	INVESTMENT INCOME	0.00	0.00	300.00	300.00	0.00
3673	SALE OF FIXED ASSETS	0.00	0.00	0.00	0.00	0.00
	<b>Total Revenues</b>	<b>111,850.00</b>	<b>111,850.00</b>	<b>298,000.00</b>	<b>186,150.00</b>	<b>(0.38)</b>
<b>Expenses</b>						
4703	SOCIAL SECURITY	247.65	247.65	11,500.00	11,252.35	0.02
4704	STAFF SALARIES	3,237.36	3,237.36	45,750.00	42,512.64	0.07
4705	MAIN/TRAIN-SALARIES	0.00	0.00	15,000.00	15,000.00	0.00
4706	OFFICER SALARIES	0.00	0.00	15,000.00	15,000.00	0.00
4707	FIREFIGHTERS SALARY	0.00	0.00	74,000.00	74,000.00	0.00
4708	DEFERRED COMPENSA	0.00	0.00	5,900.00	5,900.00	0.00
4709	MEDICAL-FIREFIGHTER	273.00	273.00	6,700.00	6,427.00	0.04
4727	OFFICE SUPPLIES	170.67	170.67	2,900.00	2,729.33	0.06
4728	BUILDING SUPPLIES	363.01	363.01	900.00	536.99	0.40
4740	OPERATING SUPPLIES	0.00	0.00	0.00	0.00	0.00
4741	EQUIPMENT SUPPLIES	145.18	145.18	8,650.00	8,504.82	0.02
4801	CONTRACT SERVICES	50.00	50.00	7,700.00	7,650.00	0.01
4820	80th Anniversary	0.00	0.00	0.00	0.00	0.00
4850	COMMUNICATIONS	200.90	200.90	4,200.00	3,999.10	0.05
4910	INSURANCE	18,097.00	18,097.00	29,900.00	11,803.00	0.61
4920	UTILITIES	(28.06)	(28.06)	17,000.00	17,028.06	0.00
4960	EDUCATION & TRAININ	160.00	160.00	7,060.00	6,900.00	0.02
4970	OFFICE EQUIPMENT	0.00	0.00	240.00	240.00	0.00
4976	FIRE EQUIPMENT	(1,173.52)	(1,173.52)	23,500.00	24,673.52	(0.05)
4978	FIRE EQUIP.-MAINT/REP	0.00	0.00	18,700.00	18,700.00	0.00
4979	FIRE EQUIPMENT-UPGR	0.00	0.00	1,750.00	1,750.00	0.00
4981	APPARATUS	0.00	0.00	0.00	0.00	0.00
4982	Loose Equip. New Apparatu	0.00	0.00	0.00	0.00	0.00
4983	Misc. Upgrades	0.00	0.00	0.00	0.00	0.00
4984	COMPUTER EQUIPMEN	0.00	0.00	900.00	900.00	0.00
4988	COMPUTER SOFTWARE/	300.00	300.00	750.00	450.00	0.40
4999	RESERVE	0.00	0.00	0.00	0.00	0.00
	<b>Total Expenses</b>	<b>22,043.19</b>	<b>22,043.19</b>	<b>298,000.00</b>	<b>275,956.81</b>	<b>0.07</b>
	Net Income/<Loss>	89,806.81	89,806.81	0.00		
3400	FUND BALANCE-Beginni	0.00	36,729.35	0.00		
	Fund Balance-End of Year	89,806.81	126,536.16	0.00		

**SWARTZ CREEK AREA FIRE DEPARTMENT  
BILLS PAID LIST**

					31-Jan-09
DATE:	CHECKS	PAYEE:	AMT	ACCT	TRANSACTION DESCRIPTION
1/5/2009	14945	BUSINESS MICRO RESOURCE	\$300.00	4988	FIRETOOLS SOFTWARE UPDATE
1/5/2009	14946	SCAFA	\$429.00 \$36.00	22024 22025	ASSOC. DUES ASSOC. PAGERS
1/5/2009	14947	FRIEND OF THE COURT	\$9.10	22026	FRIEND OF THE COURT
1/5/2009	14948	GENESEE CO FIRE CHIEFS	\$6,025.00	4960	2008 CLASSES
1/5/2009	14949	ICMA	\$541.70	22023	DF COMP EE PORTION
		(INTERNTL CITY/COUNTY MGT ASSOC.)	\$371.75	4708	DF COMP ER PORTION
1/5/2009	14950	MI ASSOC. OF FIRE CHIEFS	\$85.00	4960	MEMBERSHIP
1/5/2009	14951	PAYROLL	\$9,267.15	1002	PAYROLL-FF
1/5/2009	14952	THE STEVENSON COMPANY	\$17,891.00	4910	FLEET INSURANCE
1/12/2009	14953	CHASE	\$3,109.64	22021	12/08 SOC SEC
1/12/2009	14954	GILL ROYS	\$81.79	4741	EQUIPMENT SUPPLIES
1/12/2009	14955	GUNTHER'S LOCK SMITH	\$303.85	4728	KEYS/LOCKS
1/12/2009	14956	ICMA	\$69.42	22023	DF COMP EE PORTION
1/12/2009	14957	MCLAREN	\$273.00	4709	PHYSICALS-2
1/12/2009	14958	MML	\$206.00	4910	WC AUDIT
1/12/2009	14959	PAYROLL	\$1,004.73	1002	PAYROLL-STAFF
1/12/2009	14960	PETTY CASH	\$50.00 \$28.28 \$5.45	4801 4727 4741	CLEANING SERVICES POSTAGE EQUIPMENT SUPPLIES
1/12/2009	14961	POSTMASTER	\$84.00	4727	STAMPS
1/12/2009	14962	SHIA. CO. FF. ASSOC.	\$75.00	4960	MEMBERSHIP
1/12/2009	14963	STATE OF MICHIGAN	\$442.96	22022	12/08 STATE TAX
1/12/2009	14964	VISA	\$368.94 \$126.32 \$109.55	4727 4728 4984	OFFICE SUPPLIES, SHIPPING BUILDING SUPPLIES HARD DRIVE
1/19/2009	14965	CITY OF SWARTZ CREEK	\$1,395.85	4920	UTILITIES-STA 1 12/08
1/19/2009	14966	COMCAST	\$188.90	4850	PHONE/INTERNET-STA 1
1/19/2009	14967	CONSUMERS ENERGY	\$811.66	4920	UTILITIES-STA 2 12/08
1/19/2009	14968	SCAFA	\$12.00	4850	CHIEFS' PAGERS
1/26/2009	14969	ICMA	\$69.42	22023	DF COMP EE PORTION
1/26/2009	14970	LOWES	\$59.16	4728	BUILDING SUPPLIES
1/26/2009	14971	OFFICEMAX	\$366.41	4727	OFFICE SUPPLIES
1/26/2009	14972	PAYROLL	\$1,139.15	1002	PAYROLL-STAFF
1/26/2009	14973	SUBURBAN AUTO	\$24.96	4741	EQUIPMENT SUPPLIES
1/26/2009	14974	VALLEY PETROLEUM	\$152.74	4741	FUEL





AS OF: February 11, 2009  
TO: Swartz Creek Area Fireboard  
RECORDED BY: Fire Chief Brent Cole  
SUBJECT: Current Apparatus Readiness Status

Unit	Type	Assignment	Status
11	98 Pumper	Station 1	In service.
12	91 Pumper	Station 2	In service.
16	91 Squad	Station 1	In service.
17	79 Grass Rig	Station 1	In service.
21	99 Pumper	Station 2	In service.
23	92 Tanker	Station 2	In service.
26	93 Squad	Station 2	In service.
27	79 Grass Rig	Station 2	In service.

SWARTZ CREEK AREA FIRE DEPARTMENT  
 1100 S CIVIC DRIVE  
 SWARTZ CREEK, MI 48473

Voice: 810/635-2300  
 Fax: 810/635-7461

Bill To: CLAYTON TOWNSHIP  
 2011 MORRISH ROAD  
 SWARTZ CREEK, MI 48473

### INVOICE

Invoice Number: 020510  
 Invoice Date: Feb 5, 2009  
 Page: 1  
 Duplicate

Ship to: CITY OF SWARTZ CREEK  
 8083 CIVIC DRIVE  
 SWARTZ CREEK, MI 48473

Customer ID: CLAY01  
 Sales Rep ID

Customer PO	Payment Terms	Due at end of Month
Shipping Method	Ship Date	Due Date
Carrier		2/28/09
Description	Unit Price	Amount
FIRE SERVICE 01/09	12.37	3,272.45

Quantity	Item
264.50	FIRE02

Subtotal: 3,272.45  
 Sales Tax:  
 Total Invoice Amount: 3,272.45  
 Payment/Credit Applied:  
**TOTAL: 3,272.45**

Check/Credit Memo No

3272.45

SWARTZ CREEK AREA FIRE DEPARTMENT  
 1100 S CIVIC DRIVE  
 SWARTZ CREEK, MI 48473

Voice: 810/635-2300  
 Fax: 810/635-7461

Bill To: CITY OF SWARTZ CREEK  
 8083 CIVIC DRIVE  
 SWARTZ CREEK, MI 48473

### INVOICE

Invoice Number: 020509  
 Invoice Date: Feb 5, 2009  
 Page: 1  
 Duplicate

Ship to: CITY OF SWARTZ CREEK  
 8083 CIVIC DRIVE  
 SWARTZ CREEK, MI 48473

Customer ID: CITY01  
 Sales Rep ID

Customer PO	Payment Terms	Due at end of Month
Shipping Method	Ship Date	Due Date
Carrier		2/28/09
Description	Unit Price	Amount
FIRE SERVICE 01/09	12.30	3,253.99

Quantity	Item
264.50	FIRE02

Subtotal: 3,253.99  
 Sales Tax:  
 Total Invoice Amount: 3,253.99  
 Payment/Credit Applied:  
**TOTAL: 3,253.99**

Check/Credit Memo No

3253.99

Utility Legend

CONSUMERS ENERGY

DATE 02/11/09 BY MN NEWSOME  
 LINE BEVERIDGE TO SWARTZ CREEK

VOLTAGE 46 kV W.O. NO. 10430735  
 COUNTY GENESEE  
 TOWNSHIP GAINES  
 SECTION NO. 1  
 TOWN 06N RANGE 05E



GENESEE CO.  
 CLAYTON TWP  
 T07N, R05E  
 SEC. 36

GENESEE CO.  
 GAINES TWP  
 T06N, R05E  
 SEC. 1

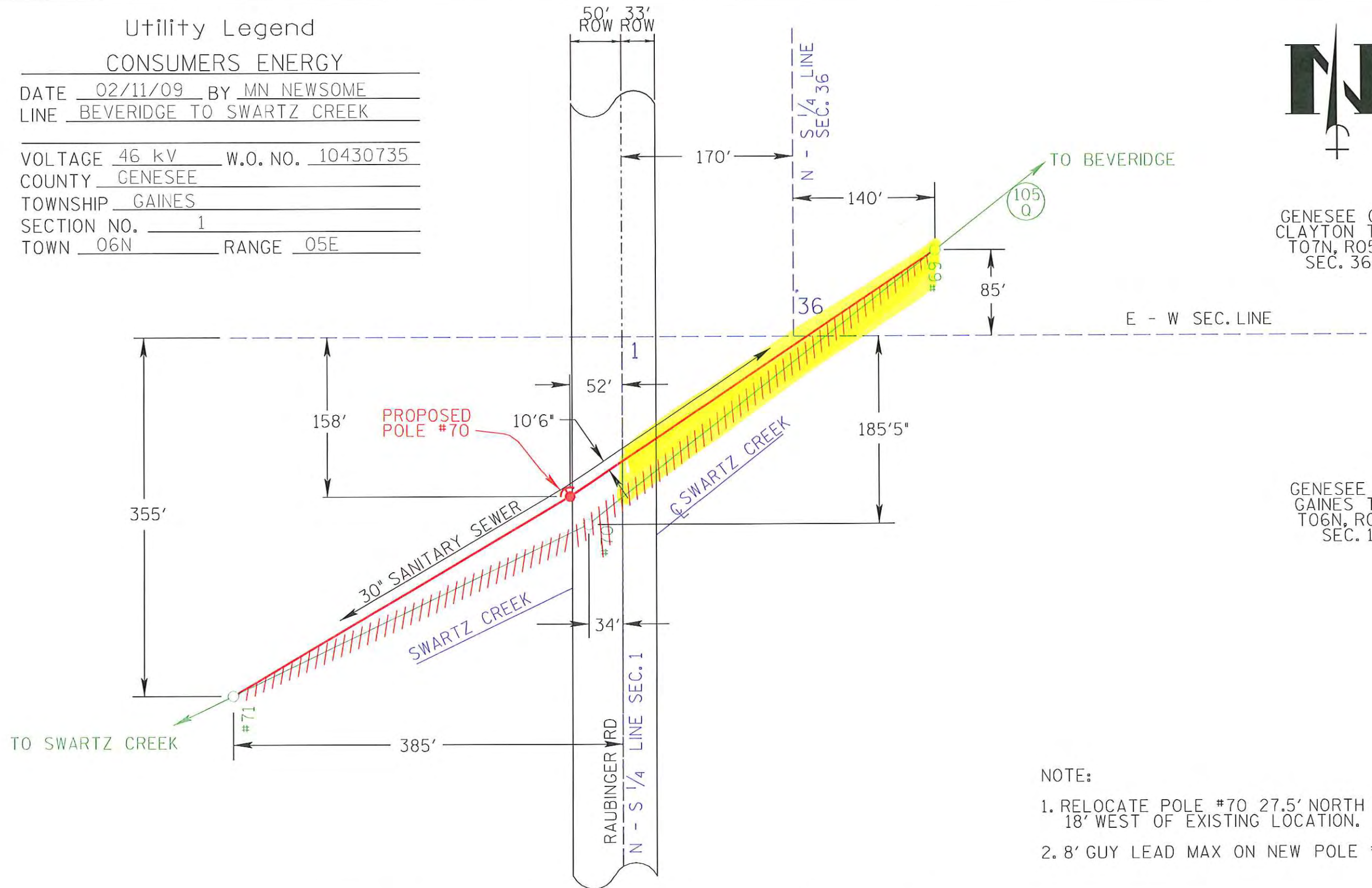

NOTE:

1. RELOCATE POLE #70 27.5' NORTH & 18' WEST OF EXISTING LOCATION.
2. 8' GUY LEAD MAX ON NEW POLE #70.

REV	DATE	DESCRIPTION	BY	APP	REV	DATE	DESCRIPTION	BY	APP

CK. MJN	2-11-09	DR. RAK	2-11-09
DSNR. MJ NEWSOME	DATE	2-11-09	
APP. ER HARVEY	SECTION HEAD	DATE	2-11-09
APP. PA MULHEARN	DIVISION HEAD	DATE	2-11-09
APP. BD BUGBEE	DEPARTMENT HEAD	DATE	2-11-09



CITY PERMIT			
BEVERIDGE TO SWARTZ CREEK			
RAUBINGER RD			
46KV LINE 105Q			
SCALE	1"=100'-0"	NO.	T04623636-B
WO	10430735	CODE	84
SHT	1	REV	

FORM SCALE = 1200  
 PLOTTING SCALE = 100  
 RS No. 52589

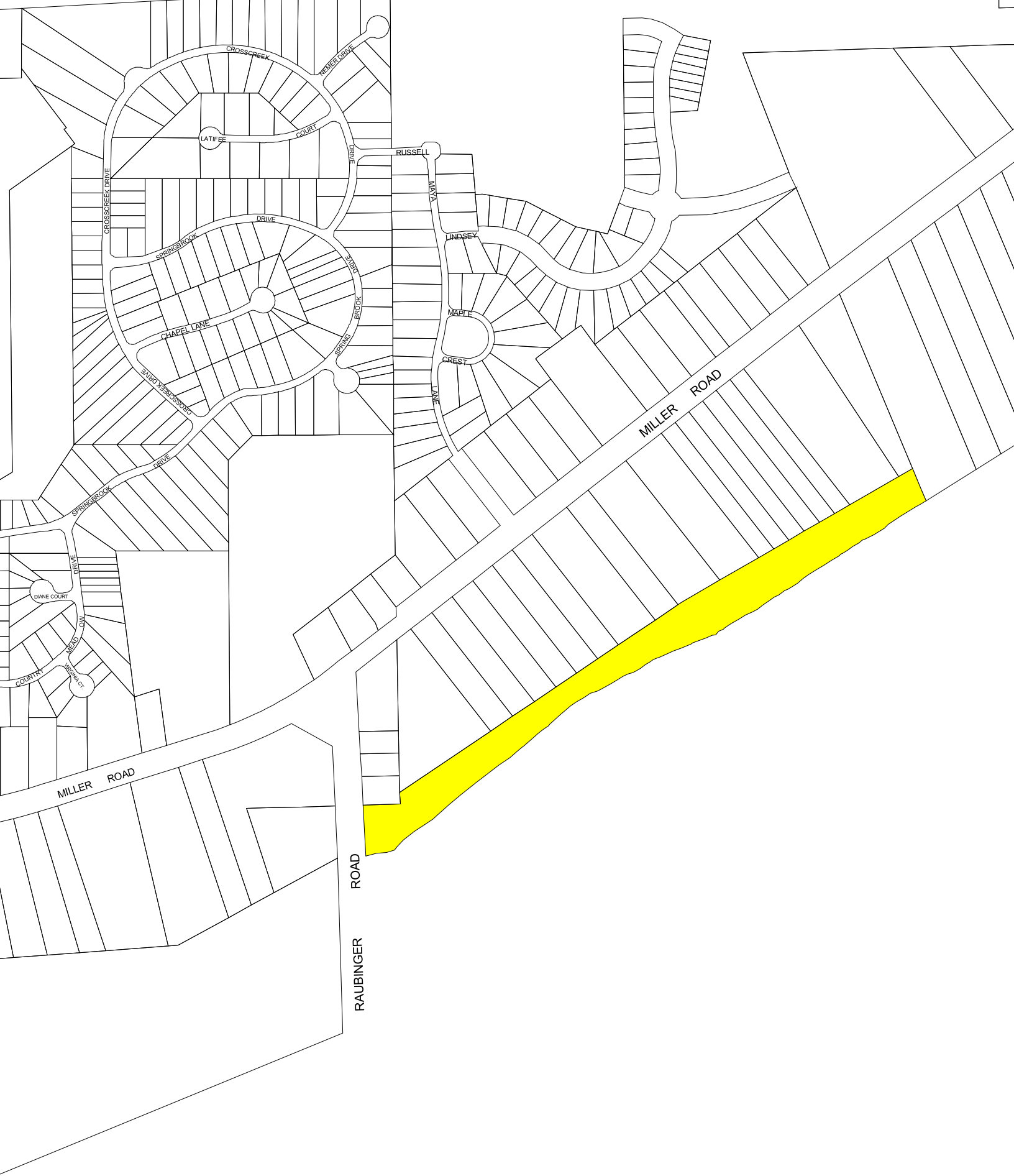







**KEEP GENESEE  
COUNTY BEAUTIFUL**

February 11, 2009

**Board of Directors**

Linda Barber  
*Mission of Peace*  
Gordon Barden  
*Village of Otisville*  
Ron Butler  
*United Way of Genesee County*  
Larry Casler  
*Genesee Intermediate  
School District*  
Dan Emerton  
*UAW Local 599*  
Greg Gaines  
*Mr. Rogers Program*  
Gary Haggart  
*Shelter of Flint*  
Kay Kelly  
*Crossroads Village  
Summer Theater Festival*  
Michael Kelly  
*Mott Community College*  
John McGarry  
*Downtown District  
Weed and Seed*  
Roxey Moreno  
*Community Volunteer*  
Cary Rouse  
*Michigan Department of  
Transportation*  
Dale Scanlon  
*Citizens Nuisance Task Force*  
John Summers  
*Community Volunteer*  
Sheila Taylor  
*Genesee County Metropolitan  
Planning Commission*  
Brian VanPatten  
*Genesee County Parks and  
Recreation Commission*  
Betty Walker  
*Walker Farms & Greenhouse*  
Renee Zientek  
*UM-Flint University Outreach*

Karen West  
*Program Director*

Erin Caudell  
*Applewood Program Liaison*

Mr. Paul Bueche, City Manager  
City of Swartz Creek  
8083 Civic Dr  
Swartz Creek, MI 48473

**2009 Genesee County Household Hazardous Waste Contributions**

Dear Mr. Bueche:

Since 1993, a consortium of organizations have worked together to provide the collection of household hazardous waste. Collections are held twice per year in Genesee County. Since the start of this program, over 1.5 million pounds of hazardous wastes have been collected and properly disposed of from county residents.

The spring and fall events in 2008 collected over 80,000 pounds of hazardous waste at a cost of \$31,763. The next collection is scheduled for **May 9, 2009** at Lake Fenton High School.

In the past, the donations to help finance these collections have been donated to the Genesee County Recycling Coalition. Last year, the Genesee County Recycling Coalition was dissolved and their assets and programs were absorbed by the Keep Genesee County Beautiful Program with the United Way of Genesee County serving as their fiduciary (at no cost).

We thank you for the assistance that you've provided in the past to help make this program possible! If you have not donated financially in the past, please consider doing so this year. As this program becomes more successful in removing harmful materials from the environment, the cost to dispose of larger quantities also increases. We are looking for your support again this year to continue these collections. Please see the suggested donation amount below which is based on the size of your community.

This program continues to be successful with your assistance, local volunteers, and support from Genesee County, the Genesee County Metropolitan Planning Commission, the Genesee County Health Department, General Motors, UAW Local 599, and several other local organizations. Should you have any questions regarding the use of the funding or the collection events, please contact Mr. Rob Loose at the Genesee County Health Department at 810-257-3612.

Thank you,

Karen West, Director  
Keep Genesee County Beautiful

## 2009 Household Hazardous Waste Program Contribution

In order to make the 2009 Household Hazardous Waste Collections possible, your support in the amount of \$ 750.00 is needed by **March 30, 2009**.

Please complete this section and return it with your donation. A receipt will be sent to you in return for your donation.

Municipality City of Swartz Creek

Contact Person Mr. Paul Bueche, City Manager

Address 8083 Civic Drive, Swartz Creek, MI 48473

Phone Number (810) 635-4464

Email Address \_\_\_\_\_

Thank you for your support!

Please make checks payable to **Keep Genesee County Beautiful** and mail to:

**Keep Genesee County Beautiful  
Household Hazardous Waste Program  
432 N. Saginaw, Suite 1001  
Flint, MI 48502**

**Annual Membership, Genesee County Recycling Coalition**

**Resolution No. 080211-09**

**(Carried)**

Motion by Councilmember Shumaker  
Second by Councilmember Hurt

I Move the City of Swartz Creek continue its membership in the Genesee County Recycling Coalition and further, approve the annual membership payment of \$750 to the organization.

Discussion Took Place.

YES: Christie, Hicks, Hurt, Porath, Shumaker, Abrams, Adams.  
NO: None. Motion Declared Carried.



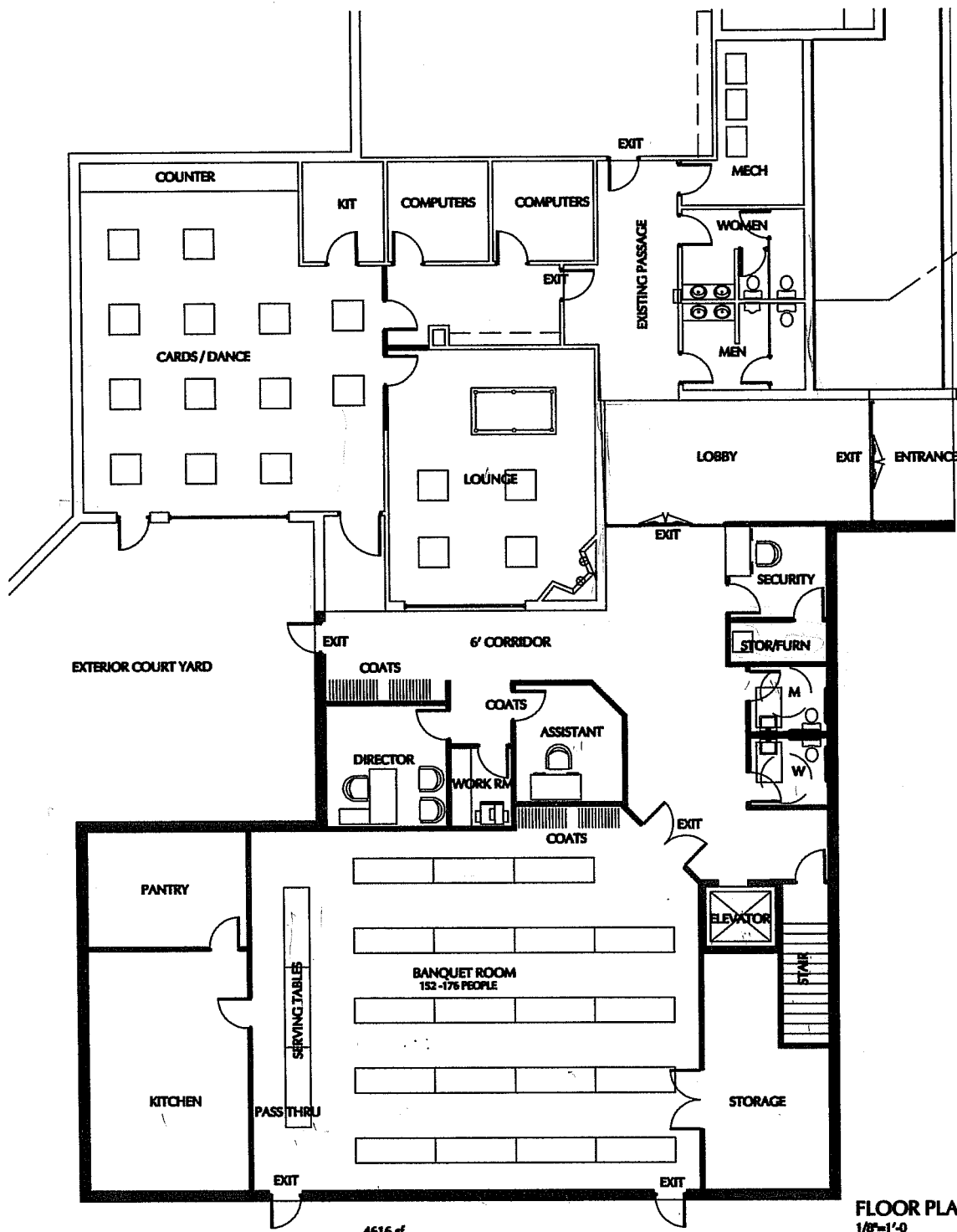

2-6-2009 Florence & Stephens Main Floor Footprint

**PROJECT DATA**

EXISTING BUILDING AREA = 5,080  
 ADDITION AREA = 7,502  
 MAIN FLOOR 4616  
 BASEMENT 2886  
 TOTAL MAIN FLOOR = 9,696 SF  
 TOTAL BUILDING AREA = 12,582 SF

LIBRARY NET AREA = 1,998  
 SENIOR CENTER NET AREA = 6,708  
 COMMON AREA (NET) = 990

NEW PARKING LOT AREA = 6,900

USE GROUP A3  
 CONSTRUCTION TYPE 5B

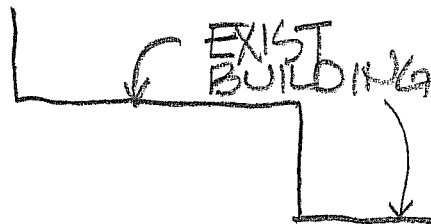

**PARKING REQUIREMENTS**

SENIOR CENTER  
 MAIN FLOOR 6708 SF / 100 = 67 SPACES  
 BASEMENT (WAREHOUSE) 2886 SF / 1500 = 2 SPACES

LIBRARY  
 2000 SF / 350 = 6 SPACES  
 CITY OFFICES  
 8300 SF / 1000 x 4 = 34 SPACES  
 TOTAL SPACES REQUIRED = 109 SPACES  
 TOTAL SPACES PROVIDED = 103 SPACES

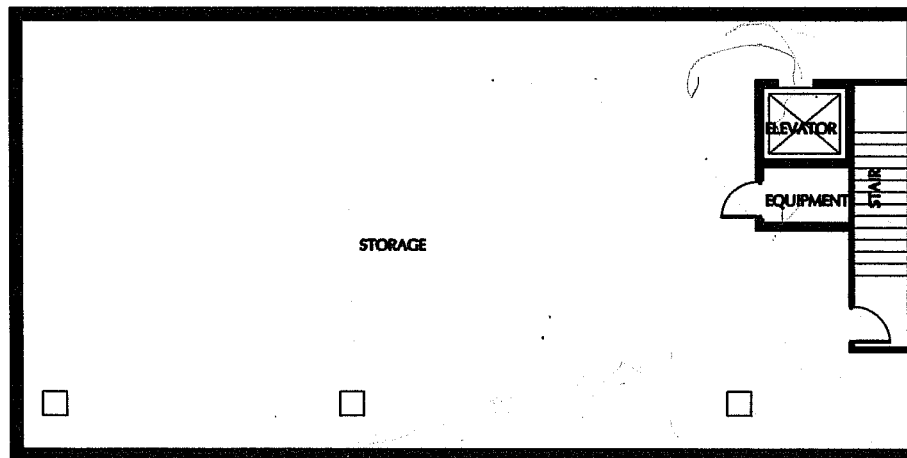

2886 sf

**BASEMENT PLAN**

2-6-2009 Florence & Stephens Basement Footprint

## PROJECT DATA

EXISTING BUILDING AREA = 5,080  
ADDITION AREA AREA = 7,502  
    MAIN FLOOR 4616  
    BASEMENT 2886  
TOTAL MAIN FLOOR = 9,696 SF  
TOTAL BUILDING AREA = 12,582 SF

LIBRARY NET AREA = 1,998  
SENIOR CENTER NET AREA = 6,708  
COMMON AREA (NET)= 990

NEW PARKING LOT AREA = 6,900

USE GROUP A3  
CONSTRUCTION TYPE 5B



## PARKING REQUIREMENTS

SENIOR CENTER  
    MAIN FLOOR 6708 SF / 100 = 67 SPACES  
    BASEMENT (WAREHOUSE) 2886 SF / 1500 = 2 SPACES

LIBRARY  
    2000 SF / 350 = 6 SPACES  
CITY OFFICES  
    8500 SF / 1000 x 4 = 34 SPACES  
TOTAL SPACES REQUIRED = 109 SPACES  
TOTAL SPACES PROVIDED = 103 SPACES

# 4616 Sq Ft + 2880 sf Basement

## CONSTRUCTION COST ESTIMATE

Swartz Creek Senior Center 2,008.11

02 06 09

Hull Stephens and Associates, Architects

	Units	\$/Unit	Totals	SCSC	CITY
Site Preparation			20,000.00	6,666.67	13,333.33
Site Utilities	500	60.00	30,000.00	10,000.00	20,000.00
Demolition			30,000.00		
Renovations			50,000.00	16,666.67	33,333.33
Building Addition	4616	75.00	346,200.00	346,200.00	
Sprinkler System	9696	2.00	19,392.00	5,817.60	13,574.40
Kitchen Equip			10,000.00	10,000.00	
Elevator	1	60,000.00	60,000.00		60,000.00
Unfinished Basement	2886	50.00	144,300.00		144,300.00
Landscaping			5,000.00	5,000.00	
Contingencies			60,000.00	36,000.00	24,000.00
Performance Bond			19,372.30	11,623.38	7,748.92
<b>TOTAL CONSTRUCTION COST</b>			<b>794,264.30</b>	<b>447,974.31</b>	<b>316,289.99</b>
\$ / SF			172.07	97.05	68.52
Professional Fees			55,598.50	31,358.20	22,140.30
Furniture and Window Cover			30,000.00	30,000.00	
<b>TOTAL COST</b>			<b>879,862.80</b>	<b>509,332.52</b>	<b>338,430.29</b>
Ratio			1.00	-0.58	0.42
Total SCSC Floor Area	6708				
Deduct performance bond			860,490.50		
Self Contract			791,651.26		

**Paul Bueche**

---

**From:** Doug Stephens [doug@hsaa.com]  
**Sent:** Wednesday, February 18, 2009 11:30 AM  
**To:** Paul Bueche; Adam Zettel; Jim Florence  
**Subject:** Senior Center  
**Attachments:** 2008.11 STORAGE GARAGE.pdf

Jim, Paul, Adam

Attached is an idea to incorporate a separate storage building to the South of the Senior Center addition. This is drawn at 28'x48', but could obviously be adjusted. It provides a garage for the Senior Center van, as well as quite a bit of storage. In the future the back storage could be incorporated into a wood shop or something. The building could be designed attractively so that it doesn't look out of place. I'm suggesting a covered porch on the North side facing the Senior Center with a landscaped courtyard between the two buildings. This will give the complex some character. With no heat or interior finishes, I think this could all be built for less than \$50,000.

I'd like your thoughts on this.

Douglas L Stephens  
Hull Stephens and Associates Architects  
5023 Holland Drive  
Swartz Creek, Mi 48473  
810 635 4090  
[doug@hsaa.com](mailto:doug@hsaa.com)

REAR BUILDING SETBACK

797.0

198.0

199.0

800

EXISTING SIDEWALK

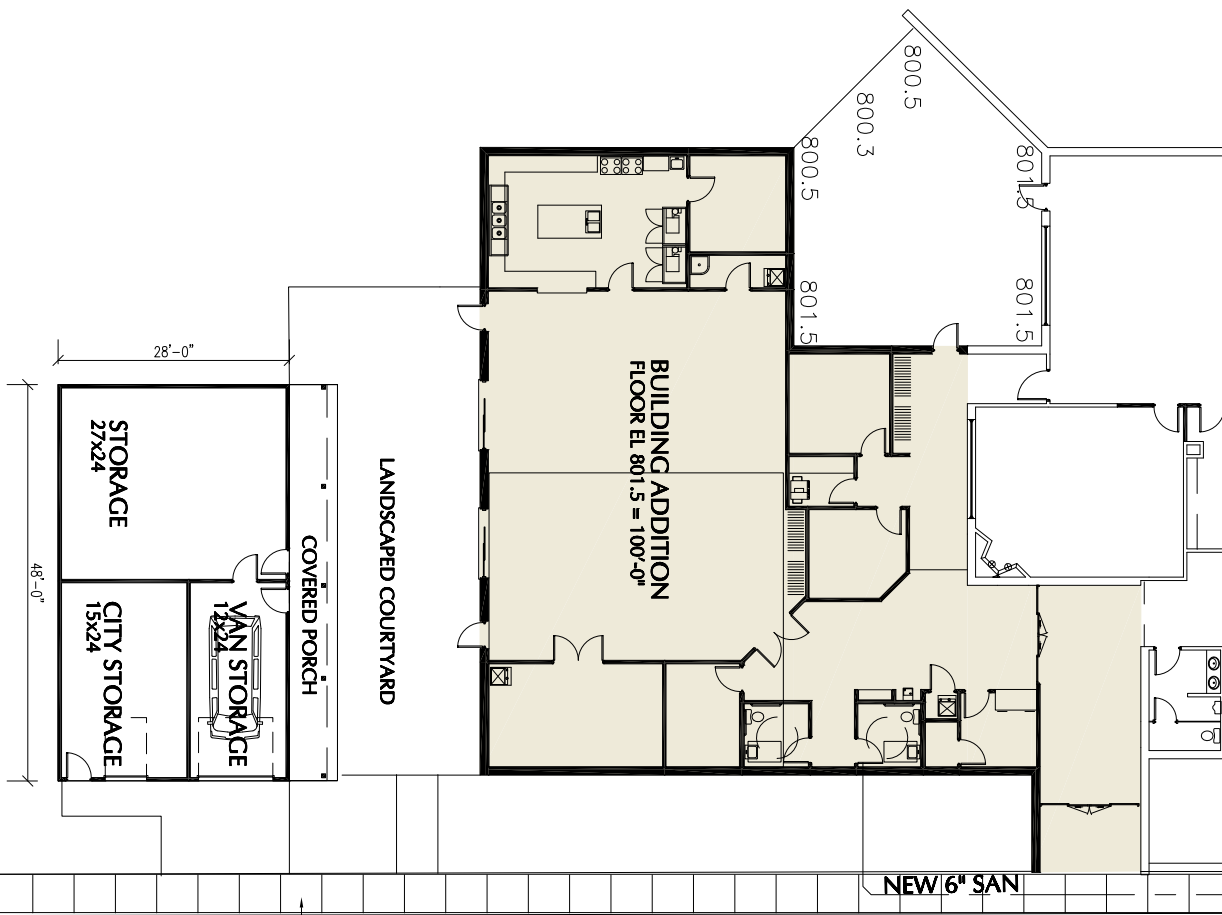

North →

REPLACE EXISTING 5' WIDE SIDEWALK AND CURB

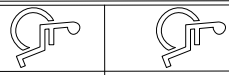
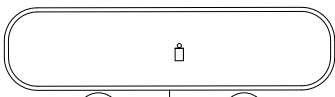

EXIST VAN ACCESSIBLE

ERN

2-18-2009 / Stephens Add On Garage - Storage Area

**Senior Center Addition, Construction Concept**

**Resolution No. 081208-04**

**(Carried)**

Motion by Councilmember Hicks  
Second by Councilmember Hurt

**WHEREAS**, the Swartz Creek Area Senior Citizens Center has been in operation since 1980 and incorporated since 1982 as a public not for profit IRS 501(c)(3) entity, serving a regional area defined as the Swartz Creek School District boundaries consisting of significant portions of four Townships; Gaines, Clayton, Mundy and Flint, and the Village's of Gaines, Lennon and City's of Swartz Creek and a small portion of Flint; and

**WHEREAS**, operational and activities funding through the 1980's and 1990's was primarily based on private donation revenues with City funded housing and associated expenses; and

**WHEREAS**, a signatory effort containing 697 validated voter signatures, asking for a ballot request of 0.5 mills for services, programs and operational costs, for a period of ten years, for the voters of the City of Swartz Creek, was presented to the City Council on August 14, 2000. The City Council voted to place the request before the voters at the General Election of November 7, 2000, the electorate of the City approving the request with the first collection in July, 2001; and

**WHEREAS**, in 2001, the Swartz Creek Area Senior Citizens determined the need and desire to expand or reconstruct their facilities due to continued and anticipated membership growth, and further, have drawn conceptual plans for additions to the existing building as well as reconstruction of a new building; and

**WHEREAS**, the City Levy of 0.5 mill was replaced with a county-wide 10 year levy of 0.7 mill on August 8, 2006, to provide programs, activities and services for seniors, to-which the operational activities for the Swartz Creek Area Senior Citizens Center is funded; and

**WHEREAS**, prior to the approval of the County millage, the Swartz Creek Area Senior Citizens Center, through the City's Levy and private donations, set aside approximately \$300,000 to fund either a capital improvement project for the existing building or the construction of a new facility; and

**WHEREAS**, the cost of a new building was determined to be prohibitive and although an addition may present some logistical problems, it is the only cost feasible solution; and

**WHEREAS**, the Senior Center has retained the services of an architect and drafted two conceptual floor plans and preliminary cost estimates for an addition, copies of which are attached; and

**WHEREAS**, Genesee County Metropolitan Planning Commission, the medium through which the County Senior Levy funds are distributed, have indicated that the

Swartz Creek Area Senior Citizens Center is eligible for a \$200,000 grant for capital improvements in the form of an addition to the existing Center, such grant would bring a total of \$500,000 the Senior Center has to spend towards an expansion to the Center; and

**WHEREAS**, the Swartz Creek Senior Citizens Center has requested permission to construct an addition and assistance from the City in funding the balance of construction, estimated to be between \$300,000 and \$500,000; and

**WHEREAS**, the City is unable to make a contribution for such an amount from its General Fund, however, under certain conditions, a loan is possible from an enterprise fund such as water or sewer.

**NOW, THEREFORE, BE IT RESOLVED** that the City Council endorse the selection of Option Number A, as an addition to the Swartz Creek Senior Center Building, and further, directs the Administrative Staff to work with the Swartz Creek Area Senior Citizens Center Board, as follows:

- In conjunction with the Swartz Creek Area Senior Citizens Center, initiate formal application to Genesee County for a grant in the maximum amount allowable.
- Prepare a draft lease between the City and the Swartz Creek Senior Citizens Center.
- Prepare a draft loan agreement between the General Fund and an appropriate enterprise fund.
- Prepare a construction budget.
- Prepare a revised draft of the Senior Citizens Center Budget.
- Initiate site plan review process.

**BE IT FURTHER RESOLVED**, that upon completion of each of the directives and any other data that may be needed, that they be brought back before the City Council for review, and further, upon collection of all data, information and commitments, a final decision by the City shall be rendered.

**BE IT FURTHER RESOLVED**, that the City Council hereby finds and determines that the making of the proposed building improvements for the use of the Swartz Creek Area Senior Citizens, Inc. constitutes actions directed toward the improvement of the social, legal, health, housing, educational, emotional, nutritional, recreational, or mobility status of older persons within the purview of 1976 PA 39 [MCL 400.571 *et seq*].

Discussion Took Place.

YES: Krueger, Porath, Shumaker, Abrams, Binder, Hicks, Hurt.  
NO: None. Motion Declared Carried.



## Paul Bueche

---

**From:** Holland, June P (JUNE) [june.holland@verizon.com]  
**Sent:** Wednesday, February 11, 2009 11:31 AM  
**To:** Paul Bueche  
**Cc:** Stewart, Richard G (RICHARD)  
**Subject:** Bristol Road Stom Sewer Project; Freedom of Information Act Request  
**Attachments:** Swartz Creek FOI letter 021109.pdf

Mr. Bueche:

Per Mr. Stewart's request I am forwarding the attached letter to you (original to follow via overnight mail). Please call if you have any questions.

Thank you,

June Holland

Executive Assistant to

Richard Stewart

**VERIZON LEGAL DEPARTMENT**

HQE03J38

P: 972-718-5331

F: 972-719-2146

Note: THIS MESSAGE MAY CONTAIN PRIVILEGED AND CONFIDENTIAL INFORMATION INTENDED ONLY FOR THE INDIVIDUAL(S) OR ENTITY TO WHICH IT IS ADDRESSED. IF YOU ARE NOT THE INTENDED RECIPIENT OR THE PERSON RESPONSIBLE FOR DELIVERY OF THIS MESSAGE TO THE INTENDED RECIPIENT, PLEASE DELETE THIS MESSAGE AND DO NOT DISTRIBUTE, COPY OR RETAIN. PLEASE NOTIFY THE SENDER IMMEDIATELY BY TELEPHONE OR EMAIL.

Richard G. Stewart, Jr.  
Assistant General Counsel  
Sales and Operations



Legal Department  
HQE03J28  
600 Hidden Ridge  
Irving, Texas 75038

Phone 972 718-7713  
Fax 972 719-2146  
richard.stewart@verizon.com

February 11, 2009

**VIA FEDERAL EXPRESS**

Paul Bueche, City Manager  
City of Swartz Creek  
8083 Civic Drive  
Swartz Creek, Michigan 48473-1377

Re: **Bristol Road Storm Sewer Project; Freedom of Information Act Request.**

Dear Mr. Bueche:

Pursuant to the Michigan Freedom of Information Act, I respectfully request copies of the following documents related to City of Swartz Creek invoice # 0800004416 and your September 15, 2008 letter:

- Documentation of cost over-runs purportedly caused by Verizon;
- A copy of the DiPonio/MDOT contract;
- Communications, letters, emails, notes with respect to Diponio's claim of logistical problems as well as safety concerns with respect to the Bristol Road Re-Surfacing Project;
- The design change initiated by DiPonio and approved by the city engineer;
- Diponio's grievance and any related documents alleging significant change in the contract;
- MDOT's award of an additional fee of \$45,000;
- Documentation which supports the allegation in your September 15, 2008 letter that the original installation of Verizon's utility poles was substandard and poor and that they remain much too close to the roadway and have little support at the base.
- Documentation of the use of "tax-payer" road repair funds for this project;
- Documentation which supports the assertion that pole bases erode during rainfall causing the structure to continue to lean.

Please forward the requested documents to the address above and please let me know if you have any questions.

February 11, 2009  
Page 2

Sincerely,



Richard G. Stewart, Jr.

RGS:jph

c: Brian Riley  
Robert Hayes  
Richard Figura, Swartz Creek City Attorney



SWARTZ CREEK CITY HALL  
 8083 CIVIC DR  
 SWARTZ CREEK, MI 48473

(810) 635-4464

# INVOICE

CUST #: 000137  
 INVOICE #: 0800004416  
 SERVICE DATE: 03/08/2006  
 INVOICE DATE: 09/18/2008  
 DUE DATE: 10/18/2008

VERIZON ACCOUNTS PAYABLE  
 224 WEST EXCHANGE STREET  
 OWOSSO MI 48867

PROPERTY ADDRESS

QTY	DESCRIPTION	Office Use	UNIT PRICE	AMOUNT
1.000	MISCELLANEOUS BRISTOL ROAD  RE-SURFACING PROJECT		45,000.0000	45,000.00
<b>TOTAL INVOICE:</b>				<b>45,000.00</b>

SWARTZ CREEK CITY HALL  
 8083 CIVIC DR  
 SWARTZ CREEK, MI 48473

(810) 635-4464

CUST #: 000137  
 INVOICE #: 0800004416  
 SERVICE DATE: 03/08/2006  
 INVOICE DATE: 09/18/2008  
 DUE DATE: 10/18/2008

VERIZON ACCOUNTS PAYABLE  
 224 WEST EXCHANGE STREET  
 OWOSSO MI 48867

PROPERTY ADDRESS





**City Offices**  
M-F 8am -5pm  
810.635.4464  
810.635.2887fax

**City Manager's Office**  
M-F 8am-5pm  
810.635.3600

**Police Department**  
Emerg. 911  
810.635.4401  
810.635.3728 fax

**Public Services Department**  
M-F-8am-4:30pm  
810.635.4495

**15-September-2008**

**Verizon Accounts Payable**  
224 West Exchange Street  
Owosso, Michigan 48867

**Re: Invoice, Bristol Road Re-Surfacing Project**

Dear **Accounts Payable**,

Attached is an invoice, net due 30 days, for cost over-runs related to the captioned project. As a brief re-cap, we designed the Bristol Road project using federal and state gas & weight tax grant funds with matching municipal funding. The project included mill, re-surfacing, shoulder re-construction and improvements to ditching to allow for road surface drainage. Verizon had existing utility poles within the ditch that needed relocating, both for construction and safety, due to close proximity to the roadway. Throughout the MDOT approval, grade inspection, bid and award phase of the project, Verizon was notified, sent plans and requested to attend a number of meetings. Verizon chose not to attend and when contacted, had no input or declined comment stating they would get back with us. The project was awarded to DiPonio Construction of Shelby Michigan by MDOT and a contract signed. At a pre-construction meeting shortly before commencement of construction, Verizon stated they would not re-locate utility structures and in fact, would invoice the City for any damage (Verizon letter dated 3/8/2006, Adam White). Verizon later changed position and stipulated that they would only "support" the structures. This decision was not acceptable to the contractor, DiPonio Construction, as they felt it presented logistical problems as well as safety concerns. A design change was initiated by DiPonio, approved by the City's Engineer that re-located the storm sewer to the north of the Verizon structures. This caused new conflicts with a buried optic fiber cable and additional expenses in time & materials. The end result is that the contractor filed a grievance with MDOT alleging significant change in the contract, asking for additional compensation. In July 2008, MDOT awarded an additional fee of \$45,000, which we subrogate to you.

The City's engineer made many attempts to get Verizon to participate in the project during the planning phase. Some of these expenses might have been unnecessary had Verizon worked with us initially. Additionally, the City feels that the original installation of the utility poles was substandard and poor. They were, and remain, much too close to the roadway and have little support at the base. As predicted by our engineer's, the pole base erodes during rainfall causing the structure to continue to lean (photo included).



*(Page 2 of 2, Verizon Invoice, September 15, 2008)*

A more viable solution would have been to re-locate the lines onto the Consumer's structures located a short distance away and out of the ditch. The City feels that tax-payer road repair funds should not go towards utility improvements or the re-location of structures that are located within the street right of way.

Sincerely,

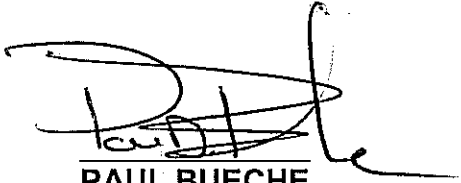
A handwritten signature in black ink, appearing to read 'Paul Bueche', with a large, sweeping flourish extending to the right.

**PAUL BUECHE**  
*City Manager*  
(810)-635-4464

Enclosures

Copy: Richard Figura, City Attorney  
Lou Fluery, City Engineer  
Verizon Engineering Manager, 340 S. Main St., Adrian Michigan 49221  
Verizon Engineering Manager, 223 Lockwood St., Alpena Michigan 49707  
Verizon Customer Service Manager, 345 Pine St., Alma Michigan 48801  
Verizon Municipal Affairs Manager, 600 Hidden Ridge, MC: HQE02E65, Irving TX. 75038



STATE OF MICHIGAN

DEPARTMENT OF TRANSPORTATION  
DAVISON TRANSPORTATION SERVICE CENTER

JENNIFER M. GRANHOLM  
GOVERNOR

KIRK T. STEUDLE, P.E.  
DIRECTOR

August 6, 2007

Mr. Cliff Rhodes  
DiPonio Construction  
51173 Simone Industrial Drive  
Shelby Twp., Michigan 48316

Dear Mr. Rhodes:

Subject: TSC Level Claim for STU25402-81682A

A Transportation Service Center (TSC) claim for project STU25402-81682A was held on July 25, 2007, at the Davison TSC. Those in attendance were:

Michael Hemmingsen	-	MDOT
Armando Lopez	-	MDOT
Phil Sekela	-	MDOT
Cliff Rhodes	-	DiPonio Construction
Frank DiPonio	-	DiPonio Construction
Michael Royalty	-	Rowe
Lou Fleury	-	Rowe
Jack Wheatley	-	Rowe

Your claim involves one issue: Increased costs due to changed physical conditions.

**CHANGED PHYSICAL CONDITIONS – FORCE ACCOUNT**

Underground utilities not shown in the contract documents were encountered between Sta. 5+37 to 40+00. The Contactor contends that the discovery of the underground utilities caused additional work associated with the installation of the storm sewer and meets the criteria of a significant change per Section 103.02.B1 of the 2003 Standard Specifications. The Contractor is requesting payment of \$52,011.15 which is the difference between the amount paid using line items (\$128,920.15), and the contractor cost per force account records (\$180,931.30).

**ENGINEER’S POSITION (ROWE)**

Section 104.07 of the 2003 Standard Specification states,



“No additional compensation will be paid to the Contractor for reasonable delay or inconvenience due to the following: C. The encountering of existing utilities shown on the plans.”

Note #8 on Plan Sheet #8 states, “The Contractor shall expose and verify the location of existing underground utilities prior to construction.” The contract proposal on page 90 states,

“The Contractor shall expose all existing utilities in critical areas. The Contractor is urged to explore any and all potential conflicts prior to construction.”

The proposal on page 90 states,

“Public utilities will not be required to relocate poles or structures in order to facilitate the operation of construction equipment unless such poles or structures constitute a hazard to the public or are extraordinarily dangerous to the contracting operation.”

Working around underground utilities is a normal construction activity and is not a basis for additional compensation.

### **DAVISON TSC DECISION**

The contract plans do not indicate utilities in the area of the proposed storm sewer. Page 85 of the contract proposal states,

“The owner of existing service facilities that are within grading or structure limits will move them to locations designated by the Engineer or will remove them entirely from the avenue right of way.”

The Contractor should not have encountered utility conflicts according to the plans, and if utility conflicts were encountered, they should have been moved according to the proposal.

The Contractor is entitled to an adjustment in unit price for the installation of the storm sewer. Per Section 103.03 of the 2003 Standard Specifications,

“An adjustment will be made when there is a change to the contract made by the Engineer as a result of the Contractor encountering a differing site condition as set forth in Subsection 103.02C or a significant change in the character of the work as set forth in subsection 103.02.B.”

The Engineer is directed to reconcile time and material records with the IDR's to determine the time and materials and equipment used only in the installation of the storm sewer, not manhole construction, etc. The Engineer will use this information to calculate costs according to Sections 103.03, A, B, C and D of the 2003 Standard Specifications to compensate the Contractor within thirty (30) days of receipt of this decision.



This represents the Davison TSC's final review of this claim. You have sixty (60) days to file a request for a Region Review if you decide to pursue this claim.

Sincerely,



Michael Hemmingsen  
Davison TSC Manager

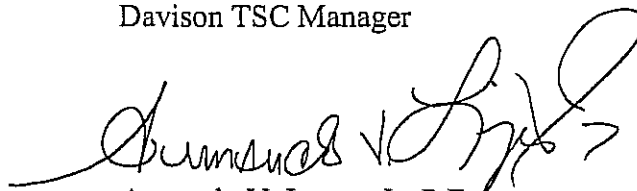

Armando V. Lopez, Jr. P.E.  
Delivery Engineer

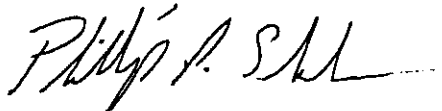

Phillip Sekela  
Staff Engineer

MH:bu  
cc: Attendees

**From:** "Phillip Sekela" <SekelaP@michigan.gov>  
**To:** "Jack Wheatley" <JWheatley@roweincorp.com>  
**CC:** "Michael Hemmingsen" <hemmingsenm@michigan.gov>, "Armando Lopez" <lopeza...>  
**Date:** 7/8/2008 4:21 PM  
**Subject:** 81682 Diponio Claim resolution  
**Attachments:** 81682 HRC calculations.pdf; 81682 diponio letter march 3 2008.pdf

Afternoon Jack,

Attached is documentation of our reasoning for the Diponio Claim settlement of \$45,000. In conclusion, Diponio's Claim was for \$199,736 as of March 3, 2008. Rowe's amount paid to Diponio is at \$149,455. The difference is \$50,281. After discussion with Diponio, they have settled for \$45,000. Please write a Contract Modification reflecting this quantity.

If you have any questions, please let us know.

Thanks,

Phillip Sekela  
Asst. Delivery Engineer  
Utilities and Permits Engineer  
Local Government Engineer  
Davison TSC  
9495 E. Potter Rd.  
Davison, MI 48423  
Office: (810) 653-7470  
Fax: (810) 653-1248



March 8, 2006

Subject: Swartz Creek - Bristol Rd Sewer Project

Dear: Lou Fleury,

Verizon will not relocate or support our poles for the sewer project on Bristol Rd. It will be the responsibility of the contractor to support the poles. Any damage to Verizon facilities will be a billable item to the party at fault.

Any questions regarding the work can be directed to me at (989-723-0241).

Sincerely,

Adam White

Engineer  
Outside Plant Engineering

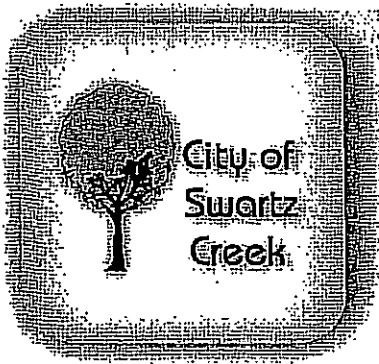

**City Offices**  
M-F 8am-5pm  
810.635.4464  
810.635.2887 fax

**City Manager's Office**  
M-F 8am-5pm  
810.635.3600

**Police Department**  
Emerg 911  
810.635.4401  
810.635.3728 fax

**Public Services Department**  
M-F 8am-4:30pm  
810.635.4495

24-March-2006

**URGENT**

Mr. **ADAM WHITE**  
C/O Verizon  
Outside Plant Engineering  
224 West Exchange Street  
Owosso, Michigan 48867

Re: **Utility Pole Relocation, Bristol Road Traffic Safety Improvement Project**

Mr. **WHITE**,

In January 2003, the City applied to the Michigan Department of Transportation (STP, STU, FHWA), via the Genesee County Metropolitan Planning Commissions' Traffic Improvement Program, for funding to crush, mill and shape a one mile section of West Bristol Road between Miller and Elms. Based on the PCI (deterioration) rating, funding was approved. Design engineering was completed in late 2004 and submitted to M.D.O.T. for approval. The original plans submitted to M.D.O.T. called for the road and shoulder width to remain unchanged. M.D.O.T. engineers rejected the plan stipulating that the shoulder width must meet AASHTO Standards. The City filed for exception and was rejected. New plans, calling for 6 Ft. shoulders in compliance with AASHTO Standards, were submitted. This plan was approved.

The City began meeting with Verizon Representatives in mid 2004 asking for utility pole relocation. A number of meetings were scheduled wherein Verizon representatives did not show, or stated they were not authorized to make such decisions. In meetings that Verizon representatives were present and rendered a solution, the City was led to believe that pole relocation would be accommodated where needed. In early March of 2006, a Verizon correspondence defines the project as "sewer", declines the relocation of the lines and further, threatens cost recovery if Verizon equipment is damaged.

This project is scheduled to be let for bid by M.D.O.T. in May, with construction slated for this summer. All funding has been allocated. Quite frankly, it is disturbing that Verizon would arbitrate such a decision in the 11<sup>th</sup> hour leaving no time to seek a solution or an appeal.



*(Page 2 of 2, March 24, 2006, Verizon, Utility Pole Relocation)*

The City's position is that this is a traffic improvement project on a Class A Road, the poles are located within the City's Right of Way, and they need to be relocated at the expense of Verizon. Further, the City, its contractors and sub-contractor's WILL NOT stipulate or accept ANY liability for damages and in fact, any additional cost for performing work around the poles will be invoiced to Verizon and recovery pursued.

I ask your office to evaluate this matter forthwith and provide me with a written commitment. In advance, I look to your reply

Sincerely,

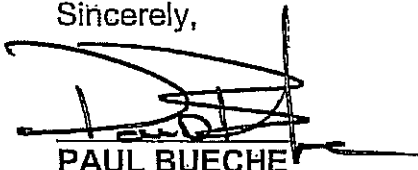
A handwritten signature in black ink, appearing to read "PAUL BUECHE", with a large, sweeping flourish extending to the left and across the top of the signature.

**PAUL BUECHE**

*City Manager  
(810)-635-4464*

Copy: RICHARD J. FIGURA, City Attorney  
JACK WHEATLEY P.E., City Engineer  
LOU FLUERY P.E., City Engineer  
JOE VIVAS, Michigan Municipal League  
LEE GONZALES, Michigan 049 House of Representatives  
ROBERT EMERSON, Michigan 037 Senate  
JESSE WARD, Verizon Engineering Manager, 340 S. Main St., Adrian MI. 49221  
Verizon Engineering Manager, 223 Lockwood St., Alpena MI. 49707  
Verizon Customer Service Manager, 345 Pine St., Alma MI. 48801  
Verizon Municipal Affairs Manager, 600Hidden Ridge, MC: HQE02E65, Irving TX. 75038

Attachment



**City Offices**  
M-F 8am - 5pm  
810.635.4464  
810.635.2887 fax

**City Manager's Office**  
M-F 8am-5pm  
810.635.3600

**Police Department**  
Emerg- 911  
810.635.4401  
810.635.3728 fax

**Public Services Department**  
M-F-8am-4:30pm  
810.635.4495

July 10, 2006

**Verizon Telephone Company**

Attn: Adam White  
224 W. Exchange Street  
Owosso, MI 48867

RE: **Bristol Road Improvements Project  
Utility Conflicts**

Dear **Mr. White**:

On June 28, 2006, and following site meeting with your representatives, a letter was sent to you regarding the utility conflicts on the Bristol Road Improvements Project. In that letter there were two options presented to your company. It was stated in the letter that Verizon Telephone Company must choose one of the options presented.

Due to time constraints on the project one week was given to select one of the two options. This one week time period has passed and there has been no response received from your company. Therefore, the storm sewer will be realigned in the conflicting areas and Verizon Telephone Company will be billed for any extra work beyond the original contract. This work will include all extra engineering cost and all extra construction time and materials. This project has been in the planning, design, bid letting, award, and preconstruction phase for three years. Verizon has been informed and invited at all phases. For reasons that are unclear, Verizon has chosen not to participate. We are out of options.

Additionally, and as you are aware, the Miller – Elms Safety Project has been let for bid and a contract awarded by MDOT. We see this project headed in the same direction, being the total lack of cooperation from your company. This project cannot be "adjusted". Utility poles must be relocated to make room for traffic signals. In the event you are unaware, this project was awarded by MDOT for safety purposes. The signal upgrades are to install dedicated left turn lanes. The intersection met the criteria for such improvements and delays due to an unwillingness to relocate utilities will serve to compromise traffic and pedestrian safety.



*(Page 2 of 2, Verizon, Utility Relocation)*

Again, and as always, we are certainly willing to discuss this, and in fact, have worked to greatly reduce Verizon's exposure to utility relocation. It appears that Verizon has assumed the position that they will not relocate utility's within the ROW for any reason. If this is true, please confirm this in writing as soon as possible.

Sincerely,

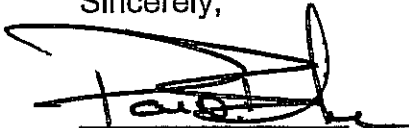

Paul Bueche  
City Manager  
(810)-635-4464

Copy: RICHARD J. FIGURA, City Attorney  
JACK WHEATLEY P.E., City Engineer  
LOU FLUERY P.E., City Engineer  
JOE VIVAS, Michigan Municipal League  
LEE GONZALES, Michigan 049 House of Representatives  
ROBERT EMERSON, Michigan 037 Senate  
JOHN PESTLE, Varnum, Riddering  
Verizon Engineering Manager, 340 S. Main St., Adrian MI. 49221  
Verizon Engineering Manager, 223 Lockwood St., Alpena MI. 49707  
Verizon Customer Service Manager, 345 Pine St., Alma MI. 48801  
Verizon Municipal Affairs Manager, 600 Hidden Ridge, MC: HQE02E65, Irving TX. 75038

Attachment: Previous Correspondence Dated March 24, 2006

Engineering and Planning  
Verizon – Michigan, Inc.



340 S. Main St.  
Adrian, MI 49221

**CERTIFIED MAIL, R.R.R.**

August 16, 2006

Paul Bueche  
City Manager  
City of Swartz Creek  
8083 Civic Drive  
Swartz Creek, MI 48473-1377

Re: Bristol Road Improvement Project

Mr. Bueche:

It has been brought to my attention that there are some remaining issues pertaining to the Bristol Road improvement project within the City of Swartz Creek, more specifically, a problem regarding the ability of Verizon personnel to safely support telephone poles in and along the storm sewer construction area.

After consultation by Verizon Engineering and Construction departments, it was determined that by using a line truck, Verizon could safely support the poles in question on a temporary basis to allow the city contractor to continue work in the vicinity of these poles without requiring a costly physical relocation. At a June 8<sup>th</sup>, 2006 pre-construction meeting, these intentions were addressed to: Lou Fluery of Rowe Engineering, Tom Svrcek of the City of Swartz Creek, and Frank Diponio of Diponio Construction, by Homer Gumbs of Verizon's construction department and Adam White of Verizon's engineering department. It was also mentioned that two poles would be in conflict with the proposed curb edge and these would be moved upon staking of the new curb line.

Following a meeting on June 27<sup>th</sup>, a letter was sent to Ron Toll of Diponio Construction on June 29<sup>th</sup> addressing some safety concerns of the proposed pole supporting method. This letter was reviewed by both engineering and construction staff members within Verizon and the letter attempted to clear up any safety concerns expressed by the city contractor. Since then, Verizon has received two conflicting letters from both the city and Mr. Michael Royalty of Rowe, Inc, dated July 10<sup>th</sup> and July 28<sup>th</sup>, respectively. These letters state that Verizon can either move all poles or pay penalty of \$15,000 to redesign the sewer project. In an attempt to discuss these further concerns, a subsequent voicemail to your office went unreturned on July 18<sup>th</sup>. Furthermore, we do not consider either of these purported options to be viable.

Verizon would be happy to work with the City of Swartz Creek and its contractors to do whatever is reasonably necessary so the storm sewer improvements can be completed. However, no credible reason has been brought to Verizon's attention why the poles could not be supported by a line truck on a temporary basis other than the already addressed issue of Verizon personnel being able to safely perform this task.

Please feel free to contact me at 517.265.0611 to discuss this further. I would like to work with the city to resolve this ongoing miscommunication so we can both move forward with the project.

Sincerely,

A handwritten signature in black ink that reads "Brian Riley".

Brian Riley – Section Manager

Cc: Neil Sheffler, Manager, Verizon Engineering - Michigan/Wisconsin













michigan municipal league  
**Liability and Property Pool**

February 6, 2009

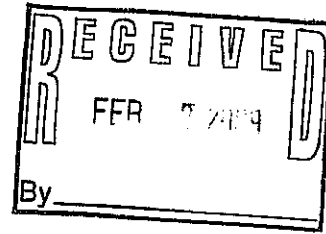

State Farm Insurance Company  
Attn: Allan Davis  
P.O. Box 2354  
Bloomington, IL 617102-2354

Re: State Farm vs. City Of Swartz Creek  
File No.: 100GL0801281  
Your File No.: 22-M408-370

Dear Mr. Davis:

Please be advised we are the claims administrators for the Michigan Municipal League Liability and Property Pool, of which the City of Swartz Creek is a member. We are in receipt of your claim for damages incurred at your residence as a result of a sewer backup occurring on or about 6/12/08. In determining the liability on behalf of any municipality we look to the proper statutes and/or case law to determine if that municipality is liable or "legally obligated" to the claim presented.

In the past, damages of this sort have found their legal basis in the pleading of "trespass nuisance." The Supreme Court has ruled on Pohutski v City of Allen Park, which concluded that trespass nuisance is not an exception to governmental immunity.

Legislation has also introduced Public Act 222 (2001) which finds governmental agencies are now responsible for direct and indirect storm or sewer back ups that are the result of a construction, design, maintenance, operation or repair defect that is more than 50% the cause of the plaintiffs damages. In order to qualify for such a claim; a property owner must meet all of the following criteria:

"a claimant may seek compensation for property damage or physical injury from a governmental agency if all of the following elements existed at the time of the event:

- a. The governmental agency was the appropriate governmental agency.
- b. The sewage disposal system had a defect.
- c. The governmental agency knew, or in the exercise of reasonable diligence should have known, about the defect.
- d. The governmental agency, having the legal authority to do so, failed to take reasonable steps in a reasonable amount of time to repair, correct, or remedy the defect.
- e. The defect was a substantial proximate cause of the event and the property damage or physical injury.

In addition to the Act stating that all five elements must exist at the time of the event, the Michigan Court of Appeals recently held, in the case entitled Willett v Waterford Township that all five elements must exist at the time of the event in order for a claim to be successfully presented against a municipality.

**Service Provider: Meadowbrook® Insurance Group**

Loss Control & Member Services: P.O. Box 5174, Southfield, MI 48037 PH: 248.358.1100 • 800.482.2726 • FX: 248.358.0534  
Southfield Claims Service: P.O. Box 5174, Southfield, MI 48086-5174 PH: 248.358.1100 • 800.482.2726 • FX: 248.358.3251  
Grand Rapids Claims: 3501 Lake Eastbrook S.E., Suite 150, Grand Rapids, MI 49546 PH: 616.942.0311 • 800.752.7477 • FX: 616.942.0390

Our investigation reveals that the cause of the sewer backup was a blockage in the main line. There was no defect in the main. As the City took reasonable steps in a reasonable amount of time to determine that the main was blocked and dislodged the blockage, we find the City is not legally obligated to your claim. Based on the above but not limited thereto, we must respectfully deny your claim.

Sincerely  
MICHIGAN MUNICIPAL LEAGUE  
LIABILITY AND PROPERTY POOL

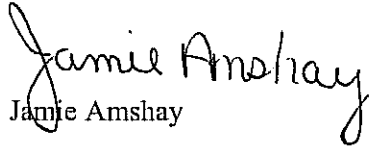
A handwritten signature in black ink that reads "Jamie Amshay". The signature is written in a cursive, flowing style.

Jamie Amshay

CC: City of Swartz Creek



**PROGRAM APPLICATION FOR LOCAL AGENCY PROJECTS  
ROAD AND SAFETY PROJECTS**

Administered through Local Agency Programs, MDOT

**PROJECT LOCATION AND LIMITS: *Attach a Map Showing the Project Location***

Eligible Applicant/Requesting Authority: City of Swartz Creek Date: September 16, 2009

Route Name: Morrish Road

Project Termini (be specific): Morrish Road from the I-69 interchange to Bristol Road

Length of project: 0.40 miles Zip Code of majority of project location\*: 48473

Is the project within urban limits?  Yes  No Which urban area? City of Swartz Creek

Is the project within City/Village limits?  Yes  No Which City/Village? City of Swartz Creek

Are other jurisdictions involved?  Yes  No If yes, identify: GCRC

Name of MPO or Rural Task Force: Genesee County MPO

Project Administration:  Bid Contract, Proposed Letting Date: April 3, 2009

Force Account, Proposed Authorization Date: \_\_\_\_\_

\*This information is required by the State Administrative Board in order to approve the agreement and construction contract for this project.

**ROUTE TYPE:** from the national functional classification system maps, prepared by MDOT, Bureau of Transportation Planning; which is available at <http://www.mdot.state.mi.us/maps/nfc>

Urban:  Principal Arterial  
 Minor Arterial  
 Urban Collector  
 Local

Rural:  Principal Arterial  
 Minor Arterial  
 Major Collector  
 Minor Collector  
 Local

On the National Highway System (NHS):  Yes  No

All Season Route:  Yes  No

**EXISTING CROSS-SECTION:**

Number of lanes: 2 at 12 feet, for a traveled roadway width, excluding curb & gutter of: 24'-0" ft

Type of Pavement: HMA

Width of sidewalks: n/a feet  One side  Both sides  None

Curb and Gutter: n/a feet  One side  Both sides  None

Shoulders: Paved Width: 0 ft  Bituminous  Concrete

Aggregate Width: 8 ft

Total shoulder Width: 8 ft per side

**PROPOSED CROSS-SECTION:**

Number of lanes: 3 at 11 feet, for a traveled roadway width, excluding curb & gutter of: 33'-0" ft

Type of Pavement: HMA

Width of sidewalks: n/a feet  One side  Both sides  None

Curb and Gutter: 3600 feet  One side  Both sides  None

Shoulders: Paved Width: 0 ft  Bituminous  Concrete

Aggregate Width: 0 ft

Total shoulder Width: 0 ft per side

Sidewalks: The MPO and/or Task Force has included sidewalks as an eligible participating item.  Yes  No

Detailed description of proposed work:

Widening of Morrish Road from I-69 to Bristol Road to three lanes with concrete curb and gutter along with the addition of mast arm traffic signals at Bristol Road and I-69 along Morrish Road.

**DESIGN GUIDELINES (Type of Project):**

Current "Michigan Department of Transportation Local Agency Programs Guidelines for Geometrics"

- Section B - New Construction/Reconstruction (4R-AASHTO)
- Section C - Resurfacing, Restoration and Rehabilitation (3R)

**Note: For 3R projects, a crash analysis and a 3 year crash report must be attached.**

- Section D - Preventative Maintenance (PM)
- Current AASHTO "Guide for the Development of Bicycle Facilities"
- Current AASHTO "Geometrics Design of Very Low Volume Roads"

Posted Speed: 40 mph      Design Speed: 45 mph

**Note: With no posted speed limit, the prima fascia speed limit applies.**

Present Average Daily Traffic: 6881, with 5 % Commercial; Future ADT 12428, with 5 % Commercial, year 2028

Present Design Hour Volume: 640, with 5 % Commercial; Future DHV 1156, with 5 % Commercial, year 2028

**ITS:** Does this project incorporate the use of Intelligent Transportation System technologies?     Yes     No  
If Yes, complete the attached ITS form, page 18.

**PARKING:**

	Prohibited	Parallel		Diagonal	
		One Side	Both Sides	One Side	Both Sides
		(Requires justification & safety analysis)			
Existing Dedicated Parking	<input checked="" type="checkbox"/>	<input type="checkbox"/>	<input type="checkbox"/>	<input type="checkbox"/>	<input type="checkbox"/>
Proposed Dedicated Parking	<input checked="" type="checkbox"/>	<input type="checkbox"/>	<input type="checkbox"/>	<input type="checkbox"/>	<input type="checkbox"/>

**RAILROAD CROSSING:**

Within project limits?     Yes     No

**BRIDGE:**

Within project limits?     Yes     No

**RIGHT OF WAY (ROW):**

Will additional ROW be required, including grading permits, temporary and/or permanent easements or right-of-entry from other jurisdictions?     Yes     No

*If Yes, then the "ROW Information Form" and Attachment "A" must be completed and submitted prior to the grade inspection, along with the Program Application. In any case, Attachment "B" must be completed and submitted a minimum of 4 weeks prior to the expected advertising date.*

**PARTICIPATING COST INFORMATION:**

<u>Approved Funding Resource(s)</u>	<u>From (S)TIP Approved Amount</u>	<u>Capped?</u>		<u>Anticipated Percentage</u>
STP – Urban	<u>\$368,000.00</u>	<input checked="" type="checkbox"/> Yes	<input type="checkbox"/> No	<u>80</u>
STP - Rural	_____	<input type="checkbox"/> Yes	<input type="checkbox"/> No	_____
Economic Development, Category _____	_____	<input type="checkbox"/> Yes	<input type="checkbox"/> No	_____
Hazard Elimination (Safety)	_____	<input type="checkbox"/> Yes	<input type="checkbox"/> No	_____
Demonstration/Special/High Priority	_____	<input type="checkbox"/> Yes	<input type="checkbox"/> No	_____
CMAQ	_____	<input type="checkbox"/> Yes	<input type="checkbox"/> No	_____
Other - Type _____	_____	<input type="checkbox"/> Yes	<input type="checkbox"/> No	_____
Local Match, Source _____	<u>\$73,600.00</u>	<input type="checkbox"/> Yes	<input type="checkbox"/> No	<u>20</u>
<b>TOTAL</b>	<u>\$441,600.00</u>			<u>100%</u>

**COST INFORMATION:**

**Estimated Participating Costs:**

Estimated cost of eligible, participating, construction **CONTRACT** items: \$441,600.00

Force account work requires an approved justification and authorization from MDOT, **PRIOR TO BEGINNING ANY WORK YOU WANT TO BE REIMBURSED FOR.**

**Eligible, participating force account work:**

Item(s) of Work	Performed by	Cost
a) _____	_____	_____
b) _____	_____	_____
c) _____	_____	_____
Subtotal of force account work:		<u>\$0.00</u>
Total Estimated Participating Cost:		<u>\$441,600.00</u>

**Estimated Non-Participating Items to be Included in the CONTRACT (do not include engineering charges or other non-contract items):**

Item(s) of Work	Cost
a) Storm Sewer Work	<u>\$95,000.00</u>
b) Other	<u>\$1,081,227.50</u>
c) _____	_____
Subtotal of Non-Participating CONTRACT Items:	<u>\$1,176,227.50</u>
<b>Total Estimated Project Cost:</b>	<u>\$1,617,827.50</u>

**PRELIMINARY ENGINEERING WILL BE PERFORMED BY:** Rowe Incorporated  
(Agency/Consultant)

**LOCAL CONSTRUCTION ENGINEERING WILL BE PERFORMED BY:** Rowe Incorporated  
(Agency/Consultant)

Prepared by: \_\_\_\_\_, P.E.  
(Signature of P.E.)

Date: \_\_\_\_\_  
Affix Licensed Professional Engineer's Seal:

Typed Name and Title: Louis P. Fleury, P.E., Project Manager

Registration Number: \_\_\_\_\_

Expiration Date: \_\_\_\_\_

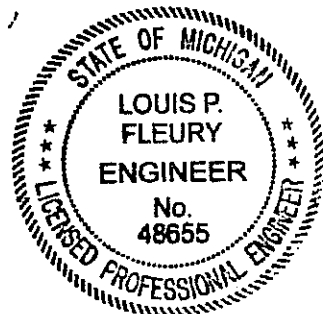

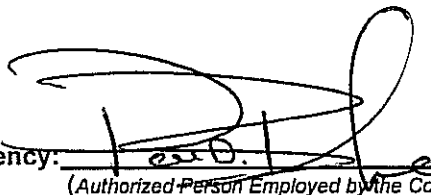
Accepted by Local Agency:   
(Authorized Person Employed by the County, City or Village)

Date: FEB 17, 2009

Typed Name and Title: Paul Bueche, City Manager



This form must be filled out, signed, sealed and certified by a Professional Engineer, prior to the grade inspection. Mark the appropriate column in the following evaluation. If the project will have a **MAJOR IMPACT** on an item below, attach a description of the effect on a separate sheet. For information regarding these factors, please refer to the Code of Federal Regulations, Highways (23CFR), available on-line from the National Archives at <http://www.archives.gov>

<u>FACTOR</u>	<u>NO IMPACT</u>	<u>MINIMAL IMPACT</u>	<u>MAJOR IMPACT</u>
Land Use	<input checked="" type="checkbox"/>	<input type="checkbox"/>	<input type="checkbox"/>
Planned Growth	<input type="checkbox"/>	<input type="checkbox"/>	<input checked="" type="checkbox"/>
Traffic Volumes*	<input type="checkbox"/>	<input type="checkbox"/>	<input checked="" type="checkbox"/>
Traffic Patterns*	<input type="checkbox"/>	<input type="checkbox"/>	<input checked="" type="checkbox"/>
Activity/Development Patterns (public transit)	<input checked="" type="checkbox"/>	<input type="checkbox"/>	<input type="checkbox"/>
Other Transportation Modes	<input checked="" type="checkbox"/>	<input type="checkbox"/>	<input type="checkbox"/>
4(f) Resources (publically owned recreation areas)	<input checked="" type="checkbox"/>	<input type="checkbox"/>	<input type="checkbox"/>
Relocation of People or Businesses	<input checked="" type="checkbox"/>	<input type="checkbox"/>	<input type="checkbox"/>
Noise Quality	<input checked="" type="checkbox"/>	<input type="checkbox"/>	<input type="checkbox"/>
Air Quality	<input checked="" type="checkbox"/>	<input type="checkbox"/>	<input type="checkbox"/>
Water Quality	<input checked="" type="checkbox"/>	<input type="checkbox"/>	<input type="checkbox"/>
Environmental Justice	<input checked="" type="checkbox"/>	<input type="checkbox"/>	<input type="checkbox"/>

\*If the project will be to construct a new roadway, the project will require the preparation of an Environmental Assessment (EA). If the project will be to add through lanes for increased capacity, the project may require the preparation of an EA. If the project will change the through capacity or level of service of a roadway, by adding or removing through lanes, you must provide an engineering study to Local Agency Programs, prior to grade inspection. If you have any questions regarding this, please contact Local Agency Programs.

**ENVIRONMENTAL EVALUATION:**

All items designated as "Within Project Limits," shall be shown on the construction plans to prevent incidental impacts during construction. Appropriate agency project clearance documents and reviews are required for the following items and **must** be kept in the project file. These are subject to monitoring review by MDOT and/or the Federal Highway Administration. The following is a list of agencies that **must** be notified by the requesting authority:

**MI Dept. of Natural Resources (MDNR)** (<http://www.michigan.gov/dnr>)

	<u>Within Project Limits</u>		<u>If Within Project Limits</u>	
	No	Yes	No Impact	Impact
State and/or Federal Natural, Wild & Scenic River	<input checked="" type="checkbox"/>	<input type="checkbox"/>	<input type="checkbox"/>	<input type="checkbox"/>
State and/or Federal Endangered Species or Habitat, Michigan Natural Features Inventory	<input checked="" type="checkbox"/>	<input type="checkbox"/>	<input type="checkbox"/>	<input type="checkbox"/>
P.A. 116 Agricultural Land	<input checked="" type="checkbox"/>	<input type="checkbox"/>	<input type="checkbox"/>	<input type="checkbox"/>
Section 6(f) Properties ( <i>properties acquired or developed with assistance of the Land and Water Conservation Act, coordinate with the US. Department of Interior - U.S. Forest Service</i> )	<input checked="" type="checkbox"/>	<input type="checkbox"/>	<input type="checkbox"/>	<input type="checkbox"/>

**MI Dept. of Environmental Quality (MDEQ)** (<http://www.michigan.gov/deq>)

	<u>Within Project Limits</u>		<u>If Within Project Limits</u>	
	No	Yes	No Impact	Impact
100 Year Base Flood Plain	<input checked="" type="checkbox"/>	<input type="checkbox"/>	<input type="checkbox"/>	<input type="checkbox"/>
Michigan Coastal Zone	<input checked="" type="checkbox"/>	<input type="checkbox"/>	<input type="checkbox"/>	<input type="checkbox"/>
Hazardous and/or Toxic Materials	<input checked="" type="checkbox"/>	<input type="checkbox"/>	<input type="checkbox"/>	<input type="checkbox"/>
Commercial Navigational River or Stream	<input checked="" type="checkbox"/>	<input type="checkbox"/>	<input type="checkbox"/>	<input type="checkbox"/>
Wetlands ( <i>NOTE, if wetlands are within project limits, you must complete the Wetland Evaluation form. If wetlands are being impacted, you must attach a Wetland Mitigation Plan</i> )	<input type="checkbox"/>	<input checked="" type="checkbox"/>	<input type="checkbox"/>	<input checked="" type="checkbox"/>

Is a National Pollutant Discharge Elimination System, Notice of Coverage (NOC) required?  No  Yes  
If "yes," you must complete the NOC form and submit it to MDEQ.

	No	Yes	No Impact	Impact
<b>U.S. Corps of Engineers (Detroit District)</b> ( <a href="http://www.usace.army.mil">http://www.usace.army.mil</a> )	<input checked="" type="checkbox"/>	<input type="checkbox"/>	<input type="checkbox"/>	<input type="checkbox"/>
<b>U.S. Coast Guard (9<sup>th</sup> District, Cleveland, Ohio)</b> ( <a href="http://www.uscg.mil">http://www.uscg.mil</a> )	<input checked="" type="checkbox"/>	<input type="checkbox"/>	<input type="checkbox"/>	<input type="checkbox"/>
Commercially Navigable Waters	<input checked="" type="checkbox"/>	<input type="checkbox"/>	<input type="checkbox"/>	<input type="checkbox"/>
<b>U.S. Fisheries and Wildlife</b> ( <a href="http://www.fws.gov">http://www.fws.gov</a> )	<input checked="" type="checkbox"/>	<input type="checkbox"/>	<input type="checkbox"/>	<input type="checkbox"/>
Federal Listed Endangered Species or Habitat	<input checked="" type="checkbox"/>	<input type="checkbox"/>	<input type="checkbox"/>	<input type="checkbox"/>
<b>Michigan State Historic Preservation Office (SHPO)</b> ( <a href="http://www.michigan.gov/shpo">http://www.michigan.gov/shpo</a> )				
Section 106, Historic or Archeological Sites, in accordance with the 8-03-05 "Final Guidance for Projects Exempt from SHPO Review".	<input checked="" type="checkbox"/>	<input type="checkbox"/>	<input type="checkbox"/>	<input type="checkbox"/>
<b>U.S. Dept. of Agriculture, National Resource Conservation Service (USDA/NRCS)</b> ( <a href="http://www.RCDnet.org">http://www.RCDnet.org</a> )				
Prime or Unique Farmland (only for federal-aid projects which require more than one acre of new ROW)	<input checked="" type="checkbox"/>	<input type="checkbox"/>	<input type="checkbox"/>	<input type="checkbox"/>
Does this project require more than one acre of new ROW?			<input checked="" type="checkbox"/> No	<input type="checkbox"/> Yes

**Local Park Authority**

Publicly Owned Parks and/or Recreation Areas	<input checked="" type="checkbox"/>	<input type="checkbox"/>	<input type="checkbox"/>	<input type="checkbox"/>
Privately Owned Recreation Areas Open to the Public	<input checked="" type="checkbox"/>	<input type="checkbox"/>	<input type="checkbox"/>	<input type="checkbox"/>
Designated Wildlife and/or Waterfowl Refuge Areas	<input checked="" type="checkbox"/>	<input type="checkbox"/>	<input type="checkbox"/>	<input type="checkbox"/>

For projects which have impacts on the above Section 4(f) properties, the local agency will prepare the necessary environmental clearance in consultation with Local Agency Programs, MDOT. For bike/shared used path projects, the local agency will obtain a letter of agreement from the local park authority and retain it in the project file.

**MDOT TSC**

The local agency must submit a copy of the Grade Inspection package to the appropriate MDOT TSC office for all projects.

Is work proposed in any MDOT Owned Right-of-Way?       No       Yes

Is a MDOT Traffic Signal located within the project limits?       No       Yes

If impact to any MDOT Traffic Signal, strain poles, detectors, etc. contact MDOT's Traffic Signals Unit @ (517) 373-2324 for coordination.

All projects must be listed on either the appropriate Metropolitan Planning Organization (MPO) S/TIP or Rural Task Force S/TIP. It must either be listed individually or included as an estimated dollar amount in the appropriate General Program Account for a state wide program, on the S/TIP prior to obligation of funds.

Is the project within an MPO area?       No       Yes

Is the project listed on the appropriate MPO S/TIP or Rural Task Force S/TIP?       No       Yes

Describe any public controversy, based on environmental grounds (23 CFR):

Based on the scope of work, evaluation of the social, economic and environmental issues, and in accordance with current federal guidelines and regulations, we, the parties signed below recommend the project be classified as the following:

- Class I - Requiring preparation of an Environmental Impact Statement (23 CFR)
- Class II - Categorical Exclusion, (from 23 CFR)
- Class III - Major action, requiring the preparation of an Environmental Assessment (23 CFR)
- Programmatic Section 4(f) Evaluation (23 CFR & 49 UCS)

We hereby certify this document to be true and accurate for fulfilling federal, state and local laws, regulations and requirements and that this document has not been modified in anyway from its original form.

Prepared by: \_\_\_\_\_, P.E.  
(Signature of P.E.)

Date: \_\_\_\_\_  
Affix Licensed Professional Engineer's Seal:

Typed Name and Title: Louis P. Fleury, P.E., Project Manager

Registration Number: 48655      Expiration Date: 10/30/2010

Accepted by Local Agency: [Signature]      Date: FEB. 17, 2009  
(Authorized Person Employed by the County, City, or Village)

Typed Name and Title: Paul Bueche, City Manager

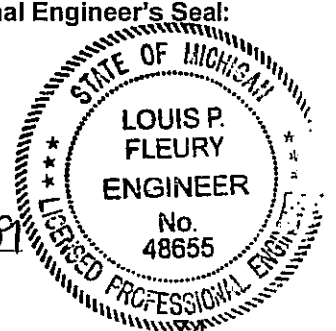

**WETLAND EVALUATION**

Contact Michigan Department of Environmental Quality (MDEQ) at <http://www.michigan.gov/deq> for a determination of wetlands and the project clearance.

- Project consists of work within designated wetlands. Fill out and submit this form prior to grade inspection.
- Project consists of NO work within designated wetlands. Skip this page and continue with remainder of form.

Route Name: Morrish Road  
 Crossing or Termini: Morrish Road from the I-69 interchange to Bristol Road

Describe the coordination with the MDEQ on the need for a permit and the proposed mitigation measures. Attach a copy of all correspondence in this regard. Do not simply reference the permit.

A permit has been submitted and obtained by the meijer corporation for the section of roadway work that will affect a wetland.

Give a general description of the wetlands involved, including the total number of acres of wetlands, the type of wetlands, their primary function, value and uniqueness and their proximity to roadway. Attach a sketch to this evaluation.

The existing wetland to be disturbed is located at the beginning of a overland county drain. The wetland serves as a detention area for water drained from Morrish Road. The approximate size of wetland that will be disturbed as a part of this project will be 0.31 acres. See proposed plan sheets.

Describe what work is proposed in the wetlands, including how the project affects the above function, value, etc. Include the reason for taking the wetlands, the approximate amount of fill and/or excavation, and acres taken. Show on an attached sketch.

The proposed work in the wetlands will include approximately 2200 Cyd's of clean fill for roadway widening. Also, an extension of an existing 4' by 4' box culvert into the wetland to allow for the roadway to be widened. See proposed plan sheets.

Attach a copy of your proposed mitigation plan and describe what alternatives were evaluated to avoid or minimize the use of the wetland. If no other alternatives were evaluated, describe why not:

No alternative were evaluated because the wetland to be disturbed is a drainage ditch. The drainage ditch will be enclosed in a box culvert.

Is a MDEQ/Corps of Engineers' Section 404, navigable waters, permit required?  No  Yes

If yes, what type of permit is required?  Nationwide  General  Individual

What design and construction measures are proposed to minimize harm to the wetlands, i.e. angle of slopes, type of erosion control, etc.? **Note: All measures required to minimize harm must be clearly identified on the project plans.**

Silt fence and riprap will be used to decrease the harm to the wetlands.

Describe other mitigation measures which are proposed to minimize harm to the wetlands (i.e. wetland replacement, enhancement, etc.):

## ATTACHMENT "A" RIGHT-OF-WAY AGREEMENT

1 of 2

**Attachment A should be submitted as part of the Program Application and will be forwarded to the MDOT Real Estate Division, Local Agency Coordinator, for review and evaluation.**

Local Public Agency: City of Swartz Creek Date: September 16, 2008  
Project: Morrish Road County: Genesee  
Crossing, from: Bristol Road to I-69 Ramp

### **Project Criteria and Information:**

Number of parcels of additional right-of-way (ROW) anticipated for this project, by type:

Fee (Total Take):	<u>0</u>
Fee (Partial Take):	<u>0</u>
Easement (Permanent):	<u>0</u>
Grading Permit (Temporary):	<u>1</u>

1. Do you understand that, if the acquisition of any additional ROW is required (including fee takes, permanent easements and/or temporary grading permits), then a fair market value must be calculated (via an appraisal, market study or value analysis) and the fair market value offer must be made to the property owner?

Yes       No

***If no, contact the MDOT Real Estate Local Agency Coordinator at (517) 373-4135.***

2. Do you understand that all ROW activities must be performed by staff that are qualified to comply with all applicable State and Federal laws and regulations, including:

- a. the Federal Uniform Relocation Assistance and Real Property Acquisition Policies Act of 1970, as amended;
- b. the provisions of 23 USC, 23 CFR and 49 CFR; and
- c. the provisions of P.A. 1980, No. 87, as amended.

Yes       No

***If no, contact the MDOT Real Estate Local Agency Coordinator at (517) 373-4135.***

3. Will a real estate Consultant /Contractor be acquiring the additional ROW for this project?  Yes       No

***If yes, list the Consultant/Contractor:*** Rowe Incorporated

**Contact person:** Louis P. Fleury, P.E.

**Telephone:** 810-341-7500

**e-mail address:** Lfleury@roweincorp.com

**ATTACHMENT "A"**  
**RIGHT-OF-WAY AGREEMENT**  
2 of 2

4. Do you anticipate the acquisition or relocation of any improvements with this project (houses, businesses, other structures or business signs)?

Yes       No

*If yes, please describe:*

5. Would you like to have a copy of the Federal Highway Administration booklet "Real Estate Acquisition Guide for Local Public Agencies" sent to you?

Yes       No

*If yes, please include your address:*

**Project Compliance Certification:**

The City of Swartz Creek \_\_\_\_\_ agrees to comply with all applicable  
(County, City, Township or Village)  
State and Federal laws and regulations when acquiring right-of-way (ROW) for this project, including:

- a. the Federal Uniform Relocation Assistance and Real Property Acquisition Policies Act of 1970, as amended;
- b. the provisions of 23 USC, 23 CFR and 49 CFR; and
- c. the provisions of P.A. 1980, No. 87, as amended.

**NOTE: Failure to comply with these regulations could jeopardize the ability to receive funding for any and all phases of this project.**

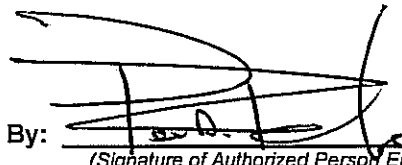
By: 

(Signature of Authorized Person Employed by the County, City, Township or Village)

Date: FEB. 17, 2009

Typed Name and Title: Paul Bueche, City Manager

Address: City of Swartz Creek  
8083 Civic Drive, Swartz Creek, MI 48473

E-Mail Address: Pbueche@cityofswartzcreek.org

Phone #: (810) 635-4464

Alternate Phone #: \_\_\_\_\_

**ATTACHMENT "B"**  
**RIGHT-OF-WAY CERTIFICATION**  
1 of 2

**Attachment B cannot be submitted to Local Agency Programs until all the additional right-of-way (ROW) has been acquired, which must be done a minimum of 4 weeks prior to the expected advertisement date.**

Local Public Agency: City of Swartz Creek Date: September 16, 2008  
Project: Morrish Road County: Genesee  
Crossing, from: Bristol Road to I-69 Ramp

**Right-of-Way Certification:**

The project **did not** require the acquisition of additional right-of-way (including fee takes, permanent easements and/or temporary grading permits). ***If this item is checked, go to Project Certification Section on the following page.***

The project **did** require the acquisition of additional right-of-way (including fee takes, permanent easements and/or temporary grading permits). The requirements of the Federal Uniform Relocation Assistance and Real Property Acquisition Policies Act of 1970, as amended; the provisions of 23 USC, 23 CFR and 49 CFR; and the provisions of P.A. 1980, No. 87, as amended, have been met with respect to this project.

- **Number of parcels of additional right-of-way (ROW) acquired for this project, by type:**

Fee (Total Take): \_\_\_\_\_  
Fee (Partial Take): \_\_\_\_\_  
Easement (Permanent): \_\_\_\_\_  
Grading Permit (Temporary): 1

- **The following documentation must be included in each parcel file:**

- Title Evidence (i.e. Title Commitment, Tax Search Documentation)
- Appraisal, Market Study and/or Valuation Analysis
- Valuation Statement and/or other documentation showing fair market value offer (just compensation) was made to the property owners
- Executed and recorded DEEDS, EASEMENTS, and/or executed GRADING PERMITS**
- Memos of Negotiation (Buyer's Communication Log)

- **The following Relocation documentation must be included in each parcel file (if applicable):**

- Relocation Eligibility Notice
- Replacement Housing Determination or Replacement Rental Determination
- Relocation Claims and Payment Documentation

ATTACHMENT "B"  
RIGHT-OF-WAY CERTIFICATION  
2 of 2

**Project Certification:**

***Certification is required regardless of whether or not the project required acquisition of additional right-of-way (including fee takes, permanent easements and/or temporary grading permits).***

The City of Swartz Creek has legal and physical possession  
(County, City, Township or Village)  
of **all** the right-of-way (ROW) necessary for the construction, operation and maintenance of this project.

***NOTE: Failure to obtain legal and physical possession of all additional ROW (executed and recorded deeds/easements, executed grading permits, or court-ordered possession agreements on condemnation parcels) will jeopardize the ability to get this project obligated, advertised and let.***

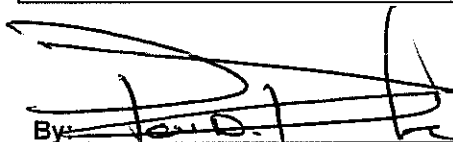
By:   
(Signature of Authorized Person Employed by the County, City Township or Village)

Date: FEB. 17, 2009

Typed Name and Title: Paul Bueche, City Manager

Address: City of Swartz Creek  
8083 Civic Drive, Swartz Creek, MI 48473 E-Mail Address: \_\_\_\_\_

Phone #: (810) 635-4464 Alternate Phone #: \_\_\_\_\_

## Project Engineer Professional Registrations and Certifications

1 of 2

This form must be filled out, signed, sealed and certified by the Project Engineer prior to advertising the project for letting.

Route Name: Morrish Road

Crossing or Termini: Morrish Road from the I-69 interchange to Bristol Road

There will be 1 (number) Professional Engineer(s), Licensed in Michigan, assigned to this project (minimum required is 1). The Professional Engineers are:

Lou Fleury

The lead Professional Engineers are also assigned to 5 other projects that will be under construction during the same time period as this project.

The number of federal aid projects administered by Local Agency Programs, MDOT, that the Professional Engineers have been assigned to as the lead role for construction engineering?

5 currently working on

25 past 5 years not including current projects

List the AASHTO Accredited Laboratory or designate the accredited testing laboratory that will be used for all required testing. If there will be more than one laboratory please list all:

Construction Testing Services

Please identify the Michigan Licensed Land Surveyor (person and company) that will be utilized for any project work that requires a licensed land surveyor:

Gilbert Bono, P.S.

There will be 2 (number) of Certified Technicians assigned to this project.

The Technicians assigned have obtained the following certifications (please check all that apply):

- Michigan Concrete Field Testing – Level 1 (MCA or MCPA)
- MDOT Density Technology Certification
- MDOT Bituminous Paving or Bituminous Paving Operations
- Michigan Certified Aggregate Technician
- Michigan Certified Bituminous Laboratory Technician (Level 1)
- Michigan Bit QC/QA Technician (Level 2)
- SESC (Soil Erosion and Sedimentation Control)
- Storm Water Operator (SWO) requirement for NPDES National Pollutant Discharge Elimination System

**Note: A copy of the NRC Nuclear Density Gauge License shall be placed in the project file for all nuclear density gauges used on the project.**

I Paul Bueche, City Manager do certify that we own and are trained or  
(Authorized Person Employed by the County, City, or Village)

have hired Rowe, Inc and Construction Testing Services

who is trained to use the following (check all that apply):

- Field Manager and necessary computer equipment;
- All necessary equipment to perform density inspection and testing as required in Sections 205 & 301-307 of the MDOT Standard Specifications For Construction, all applicable FUSP's, and MDOT Materials Quality Assurance Procedures Manual;



2 of 2

- All necessary equipment to perform aggregate inspection and testing as required in Sections 205 & 301-307 of the MDOT Standard Specifications For Construction, all applicable FUSP's, and MDOT Materials Quality Assurance Procedures Manual;
- All necessary equipment to perform hot mix asphalt testing as required in Section 501-504 of the MDOT Standard Specifications For Construction, all applicable FUSP's for hot mix asphalt, Hot Mix Asphalt QC/QA Procedures Manual of Field Testing and Materials Quality Assurance Procedures Manual; and/or
- All necessary equipment to perform Portland Cement Concrete inspection and testing as required in Sections 601-605 of the MDOT Standard Specifications For Construction, all applicable FUSP's and MDOT Materials Quality Assurance Procedures Manual.

There are 2 (number) personnel that have been assigned to this project who are knowledgeable in the use of these items (check all that apply):

- MDOT Standard Specifications for Construction
- MDOT Construction Manual
- MDOT HMA Production Manual
- Applicable Michigan Test Methods
- MDOT Road and Bridge Standard Plans
- Density Control Handbook
- Procedures for Aggregate Inspection
- MDOT Materials Quality Assurance Procedures Manual
- MDOT Hot Mix Asphalt QC/QA Procedures Manual

Failure to provide accurate documentation and/or failure to maintain the required information may immediately stop the project and may result in the withdrawal of federal and/or state funding. These actions may also impact future federal and/or state funding. The County, City or Village is required to notify the MDOT TSC Delivery Engineer, in writing, if the Project Engineer changes during the project.

Signed: [Signature]  
(Authorized person employed by the Local Agency)

Date: FEB. 17. 2009

Signed: \_\_\_\_\_  
(Project Engineer, P.E.)

Date: \_\_\_\_\_

Affix Licensed Professional Engineer's Seal:

Typed Name and Title Louis P. Fleury, Project Manager

Registration Number: 48655 Expiration Date: 10/30/2010

Address: 4400 S. Saginaw  
Flint, MI 48507

Phone No. (810) 341-7500

Email Address: Lfleury@roweincorp.com

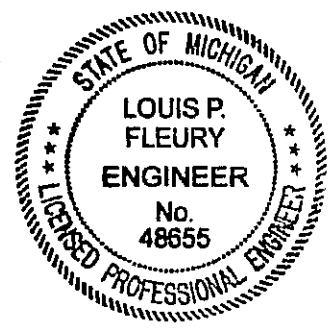

**PUBLICLY EMPLOYED PROJECT ENGINEER STATEMENT**

**Complete either: 1) this statement, or  
2) the Project Engineer Statement (page 14) and the Project Supervisor Statement (page 15)  
and Submit to Local Agency Programs PRIOR to the grade inspection**

The City of Swartz Creek has designated \_\_\_\_\_  
*(Eligible Applicant/Requesting Authority)* *(Name of Project Engineer)*

as the Publicly Employed Project Engineer for the Route Name: Morrish Road

Crossing or Termini: Morrish Road from the I-69 interchange to Bristol Road project.

Authorized Signature \_\_\_\_\_ Date: \_\_\_\_\_  
*(Authorized Person Employed by the County, City or Village)*

Typed Name and Title: Lou Fleury, P.E., Project Manager

I, \_\_\_\_\_, as the Publicly Employed Project Engineer, shall be the sole representative responsible for the project. This responsibility shall not be delegated to anyone else.

Michigan Department of Transportation personnel will, in all cases, deal directly with me, the Publicly Employed Project Engineer, during the construction phase of the project.

In this regard, the Publicly Employed Project Engineer shall (at a minimum):

- 1) Meet all the requirements for a publicly employed engineer;
- 2) Be considered in responsible charge of the project;
- 3) Sign all construction documents;
- 4) Attend the grade inspection meeting and the pre-construction meeting;
- 5) Be available for meetings with the Michigan Department of Transportation, the local agency, the certified inspectors and/or the contractor;
- 6) Assure that the plans, specifications and proposal are followed and approve any changes or modifications to the plans, specifications or proposal;
- 7) Assure that the construction inspectors are currently certified, as required;
- 8) Be a Licensed Professional Engineer in the State of Michigan; and
- 9) Be in attendance at the final project review.

Signed: \_\_\_\_\_ Date: \_\_\_\_\_  
*(Publicly Employed Project Engineer, P.E.)*

Typed Name and Title: \_\_\_\_\_

Registration Number: \_\_\_\_\_ Expiration Date: \_\_\_\_\_ Affix Licensed P.E. Seal:

Address:

\_\_\_\_\_

Phone No.: \_\_\_\_\_

Email Address: \_\_\_\_\_

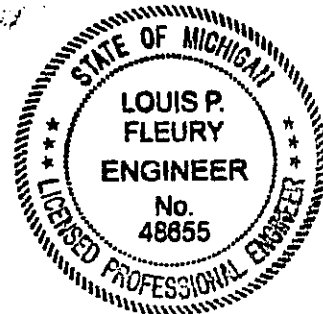

**PROJECT ENGINEER STATEMENT**

**Complete either: 1) this statement and the Project Supervisor Statement (page 15) or  
2) the Publicly Employed Project Engineer Statement (page 13)  
and Submit to Local Agency Programs PRIOR to the grade inspection**

The City of Swartz Creek has designated Louis P. Fleury, P.E.  
*(Eligible Applicant/Requesting Authority)* *(Name of Project Engineer)*

as the Project Engineer for the Route Name: Morrish Road

Crossing or Termini: Morrish Road from the I-69 interchange to Bristol Road project.

Authorized Signature \_\_\_\_\_  
*(Authorized Person Employed by the County, City or Village)* *(Date)*

Typed Name and Title: Paul Bueche, City Manager

I, Louis P. Fleury, P.E., as the Project Engineer, shall be the sole representative responsible for the project. This responsibility shall not be delegated to anyone else.

Michigan Department of Transportation personnel will, in all cases, deal directly with me, the Project Engineer, during the construction phase of the project.

In this regard I, as the Project Engineer, shall (at a minimum):

- 1) Be considered in responsible charge of the project;
- 2) Sign all construction documents;
- 3) Attend the grade inspection meeting and the pre-construction meeting;
- 4) Be available for meetings with the Michigan Department of Transportation, the local agency, the certified inspectors and/or the contractor;
- 5) Assure that the plans, specifications and proposal are followed and approve any changes or modifications to the plans, specifications or proposal;
- 6) Assure that the construction inspectors are currently certified, as required;
- 7) Be a Licensed Professional Engineer in the State of Michigan; and
- 8) Be in attendance at the final project review.

If this project will alter a roadway in any way, this Program Application, the plans, specifications, estimate and proposal must be prepared by, signed, sealed and certified by a Professional Engineer (P.E.).

Signed: \_\_\_\_\_ Date: \_\_\_\_\_  
*(Project Engineer, P.E.)*

Typed Name and Title: Louis P. Fleury, P.E., Project Manager

Registration Number: 48655 Expiration Date: 10/30/2010 Affix Licensed P.E. Seal:

Address: 4400 S. Saginaw  
Flint, MI 48507

Phone No.: (810) 341-7500

Email Address: Lfleury@roweincorp.com

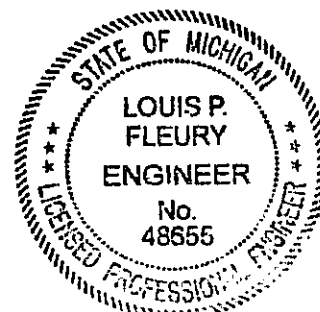

**PROJECT SUPERVISOR STATEMENT**

**Complete either: 1) this statement and the Project Engineer Statement (page 14), or  
2) the Publicly Employed Project Engineer Statement (page 13)  
and Submit to Local Agency Programs PRIOR to the grade inspection**

The City of Swartz Creek has designated Thomas Svrcek  
*(Eligible Applicant/Requesting Authority)* *(Name of Project Supervisor)*

as the Project Supervisor for the Route Name: Morrish Road

Crossing or Termini: Morrish Road from the I-69 interchange to Bristol Road project.

Authorized Signature \_\_\_\_\_ Date: \_\_\_\_\_  
*( Authorized Person Employed by the County, City or Village)*

Typed Name and Title: Paul Bueche, City Manager

In this regard, the Project Supervisor, shall (at a minimum):

1. Be a full time employee of the local agency;
2. Approve for funding all construction documents prepared and signed by the Project Engineer;
3. Attend the grade inspection meeting and the pre-construction meeting;
4. Be available for meetings with the Michigan Department of Transportation and/or the Project Engineer;
5. Be in attendance at the final project review; and
6. Assure that the project record files are maintained.

Signed:  \_\_\_\_\_  
*(Project Supervisor)*

Date: FEB. 17, 2009

Typed Name and Title: Paul Bueche, City Manager

Address: 8083 Civic Dr.  
Swartz Creek, MI 48473

Phone No.: (810) 635-4464

Email Address: \_\_\_\_\_

**RAILROAD AT-GRADE CROSSING INFORMATION**

- A railroad crossing is within the project limits. Fill out this form and submit with the Program Application.  
 A railroad crossing IS NOT within the project limits. Skip this form and continue with remainder of application.

Route Name: Morrish Road Crossing or Termini: Morrish Road from the I-69 interchange to Bristol Road

Regulatory order?  Yes  No If yes, expiration date \_\_\_\_\_

**EXISTING CROSSING DATA:**

Number of tracks \_\_\_\_\_ Angle of crossing \_\_\_\_\_  
 Trains per day \_\_\_\_\_ Speed of train \_\_\_\_\_  
 Approach roadway width \_\_\_\_\_ Number of lanes \_\_\_\_\_

Crossing protection \_\_\_\_\_

Type of crossing material \_\_\_\_\_

If no work is proposed at crossing, **stop here**, no further information is needed.

**PROPOSED CROSSING DATA:**

Number of tracks \_\_\_\_\_ Angle of crossing \_\_\_\_\_  
 Freight trains per day \_\_\_\_\_ Speed of train \_\_\_\_\_  
 Passenger trains per day \_\_\_\_\_ Speed of train \_\_\_\_\_  
 Approach roadway width \_\_\_\_\_ Number of lanes \_\_\_\_\_

Crossing protection \_\_\_\_\_

Type of crossing material \_\_\_\_\_

Will the Railroad do the signal and/or crossing work by master agreement?  Yes  No

Contact the Rail Freight Section of MDOT for details regarding the master agreement.

Start the appropriate agreement immediately.

<u>Type of Work</u>	<u>Estimated Cost</u>	<u>Federal Participation</u>
Crossing Improvement by Railroad	_____	<input type="checkbox"/> Yes <input type="checkbox"/> No
Signal Work by Railroad	_____	<input type="checkbox"/> Yes <input type="checkbox"/> No
Total Work by Railroad	_____	
Approach Work by _____	_____	<input type="checkbox"/> Yes <input type="checkbox"/> No

- The approach work is to be done by:
- Force Account
  - Negotiated Contract
  - Contract (let for bids)\*

\*Note: Contracted work must be greater than \$10,000

**RAILROAD SAFETY FUNDED PROJECTS**

For Railroad Safety funded projects, the following must be attached to the program application:

- 1) A copy of the MDOT Safety Order (contact UPTRAN, Safety & Tariffs Division, MDOT)
- 2) A copy of the latest safety inspection; and
- 3) Pictures of the crossing

**BRIDGE INFORMATION**

- A bridge IS within the project limits. Fill out this form and submit with the Program Application.
- A bridge is NOT within the project limits. Skip this form and continue with remainder of application.

**ROUTE NAME:** Morrish Road **CROSSING:** Morrish Road from the I-69 interchange to Bristol Road  
**EXISTING STRUCTURE:**

Number of spans: \_\_\_\_\_ at \_\_\_\_\_ ft. for a total overall length: \_\_\_\_\_ ft. Posted load restriction of: \_\_\_\_\_ tons  
Clear Roadway width: \_\_\_\_\_ ft. Sidewalk Width: \_\_\_\_\_ ft. Railing Type: \_\_\_\_\_  
Structure Type: \_\_\_\_\_ Approx. Year built: \_\_\_\_\_  
Can the existing structure be rehabilitated?  Yes  No

Explain: \_\_\_\_\_

**1. IF NO WORK IS PROPOSED ON THE BRIDGE:**

- A) Do the existing railings meet current AASHTO static load requirements?  Yes  No  
If No, then the railings must be upgraded or replaced and item #2, below, must be completed.
- B) Type of bridge deck: \_\_\_\_\_  
If the deck is bituminous over concrete, is there an existing waterproof membrane?  Yes  No  
If No, then it is strongly recommended that the existing bituminous be removed, an acceptable bridge deck protective system be placed on the bridge and item #2, below, be completed.
- C) The current estimated load carrying capacity meets:
  - Current AASHTO for bridges to remain in place  Current 3R Guidelines
  - Neither, complete item #2, below
- D) The current clear roadway width is \_\_\_\_\_ ft. and meets:
  - Current AASHTO for bridges to remain in place  Current 3R Guidelines
  - Neither, complete item #2, below

**2. IF WORK IS PROPOSED ON THE BRIDGE:**

If the existing clear roadway width, structural capacity or bridge railing does not meet the current 3R guidelines, then the bridge must be evaluated for widening, rehabilitation, railing upgrading and/or replacement. If the structure is to be replaced or have major rehabilitation, then it must meet current AASHTO standards for new construction and the Economic Assessment (pages 17-23) of the Program Application for Local Agency Bridge Projects must be completed and enclosed with this application).

- Proposed work:  Upgrade railings to current AASHTO requirements  Deck resurfacing  
 Deck replacement\* (major rehabilitation)  Widening\* (major rehabilitation)

\*The Economic Assessment (pages 17-23) of the Program Application for Local Agency Bridge Projects must be completed and enclosed with this application).

**3. BICYCLE OR SHARED USE PATH ON EXISTING OR NEW BRIDGE:**

- A) Will the project include a bike path(s) or share use path(s) on a bridge?  Yes  No  
If Yes, will the bridge cross section provide the required separation between the path and the roadway and/or the required clear area between the path and railings to meet the current AASHTO requirements for bicycle and/or shared used facilities?  Yes  No
- B) Is the bridge over a moving watercourse?  Yes  No  
If yes, then it is highly recommended that scour be considered and the following table must be completed:

SUMMARY OF HYDRAULIC ANALYSIS							
Existing				Proposed			
Flood Data	Discharge (cfs)	Water Surface Elev. at U/S Face of Structure (ft.)	Velocity in D/S Channel (ft./s)	Water Surface Elev. at U/S Face of Structure (ft.)	Velocity in D/S Channel (ft./s)	Waterway Area (Sq. Ft.) at D/S Face	Change in WS El. ft. U/S of Proposed Structure (ft.)
50-Year	_____	_____	_____	_____	_____	_____	_____
100-Year	_____	_____	_____	_____	_____	_____	_____
MAXIMUM BRIDGE AREA BELOW LOW CHORD IS _____ SQUARE FEET							86

## INTELLIGENT TRANSPORTATION SYSTEM INFORMATION

Fill out this form and submit it with the Program Application, if there are ITS technologies being installed within the project limits.

1. Does a Regional ITS Architecture exist. Yes  No   
If No, skip to question 4. If yes, continue.
  
2. Does the proposed ITS Architecture conform to the ITS Regional Architecture? Yes  No   
If No, skip to question 6. If yes, continue.
  
3. Has ITS Architecture Conformance Documentation, which indicates what portion of the Architecture is being implemented, been provided for the project files?  
 Yes, continue.  
 No, this information must be obtained and submitted prior to project authorization.
  
3. Has the project been included in the appropriate S/TIP? (Approved by the MPO or Rural Task Force):  
 Yes, continue.  
 No, this information must be obtained and submitted prior to project authorization.
  
4. Has the ITS Project Architecture been developed and provided for and been provided for the project files?  
 Yes, continue.  
 No, this information must be obtained and submitted prior to project authorization.
  
5. Has the agency responsible for maintaining the Regional ITS Architecture agreed to revise the Regional Architecture to include this project and/or technology?  
 Yes, continue.  
 No, this information must be obtained and submitted prior to project authorization.



MICHIGAN DEPARTMENT OF ENVIRONMENTAL QUALITY  
WATER BUREAU

**2008 WATER SUPPLY CROSS CONNECTION REPORT**

Issued under authority of 1976 PA 399, as amended, and the Administrative Rules.

Failure to submit this form is a violation of the Act and may subject the water supply to enforcement penalties.

Administrative Rule R 325.11405 states in part that "a water utility shall report annually to the department on the status of the cross connection control program on a form provided by the department." Complete this form and return it to the appropriate Michigan Department of Environmental Quality (MDEQ) district office by March 31, 2009.

WSSN: 6505

- A. Name of water utility: City of Swartz Creek County: Genesee
- B. Year that the current written cross connection control program was approved by MDEQ: 2001
- C. Total number of industrial, commercial, institutional, residential, and governmental accounts that must be routinely reinspected for cross connections: 134  
Of this number,  
- How many are High Hazard accounts: 5 Frequency of Reinspection: Once per year  
- How many are Low Hazard accounts: 121 Frequency of Reinspection: Once per: 5 years
- D. Number of accounts from "C" above that received their initial inspection in 2008: 3
- E. Total number of reinspections required and completed in 2008 based on degree of hazard:  
- High hazard reinspections required: 5 High hazard reinspections completed: 5  
- Low hazard reinspections required: 25 Low hazard reinspections completed: 29
- F. Number of accounts where a cross connection(s) was found to exist during inspections or reinspections in 2008: 7
- G. Number of accounts from "F" above where corrective actions have been completed: 0
- H. Total number of accounts from "C" above which are now in compliance with the local cross connection control program; H = C - (F - G): 119
- I. Total number of backflow prevention devices in system requiring testing: 38
- J. Number of backflow prevention devices tested in 2008: 31

Narrative Description of Program

(Outline briefly any changes or significant findings since last reporting; use additional sheets if necessary.)

See attached notes

Name/Title: \_\_\_\_\_

Signature: \_\_\_\_\_ Date: \_\_\_\_\_



## 2008 Water Supply Cross Connection Report Notes

- Testable Backflow Prevention Assemblies
  - All testable assemblies are tested on an annual basis.
  - 31 of 38 assemblies were tested in 2008. All assemblies not tested are either in the notification process or are seasonal assemblies identified after the system was winterized and are scheduled for May 2009.
  - Test notices for lawn sprinkler system / seasonal assemblies are issued in May.
- Approximately 30 inspections will be completed in 2009.
- 134 total accounts:
  - 133 of 134 accounts have been inspected.
  - 119 of 133 accounts inspected are in-compliance; the remaining 14 facilities are going through the notification process or are vacant buildings.
  - 7 vacant buildings have been identified in addition to the high and low hazard accounts listed on line item C. We have not been able to gain access to all of these facilities to verify compliance.
  - 1 New facility has been added to the account listing. This facility will be initially inspected in 2009.
- All High Hazard Facilities were inspected in 2008.

9236 Young Drive  
Swartz Creek, MI 48473  
February 5, 2009

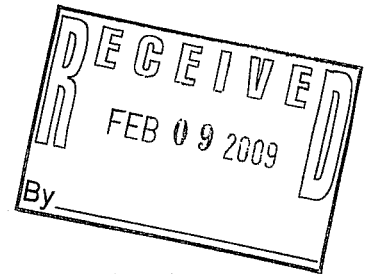

Mr. Tom Svrcek  
8083 Civic Dr  
Swartz Creek, MI 48473

Dear Mr. Svrcek,

The company hired by the city to re-structure manholes recently did the one in front of my house. I've lived at this address for twenty-four years, am familiar with how my ditch functions, and realize there will be problems in the near future.

I completely understand the reasons for the city changing these manhole covers. For some homeowners here in Winchester Woods, however, the holes in the old manhole covers were the only way for water to be eliminated from our areas. In this case, repairing the leaky manhole covers causes other problems.

According to surveyors who were out here several years ago, the neighbor to my right (as you're on the street looking at the homes), is located on the highest ground here and has no culvert, with water on each side of his home being directed into the ditch that begins on each side of his driveway. The ditch is supposed to begin a slow downward slant from his driveway, so that water can flow to the culvert at the end of the street. In my case, the water is to flow toward Oakview Drive. The water does not flow down the ditch in front of my house, but stays there - or it will stay there once the snow melts and the rains begin.

I expect to have water in my ditch - either frozen or otherwise - during the entire year from now on (except, perhaps, during the hottest, dry summer months). This will be a dangerous situation for any small children who may be playing near there, which, if the worst happened, God forbid, could result in action by parents against the city of Swartz Creek.

A personal problem I see coming in the near future is the end of my sump drain freezing, thereby causing a flooding problem in my basement. It isn't happening right now, but that's only because there is snow - not ice - in the ditch. I am in the process of rigging up an emergency way out for that water when it begins backing up into my basement.

I talked with the man who seemed to be in charge when they re-did the manholes. He said it looked to him like the ditch on the other side of my street is lower than is mine and suggested that I contact you about putting a small culvert under the street from the low spot in front of my house to the other side. I request that the city either do that or re-grade the ditch so as to achieve a proper downward slope from here to Oakview Drive.

Thank you.

A handwritten signature in cursive script that reads 'Jerry Ervin'.

Jerry H. Ervin

810-635-2084

(Lot 66 Winchester Woods)

STATE OF MICHIGAN  
BEFORE THE MICHIGAN PUBLIC SERVICE COMMISSION

NOTICE OF HEARING  
FOR THE ELECTRIC AND NATURAL GAS CUSTOMERS OF  
CONSUMERS ENERGY COMPANY  
CASE NOS. U-15805 AND U-15889

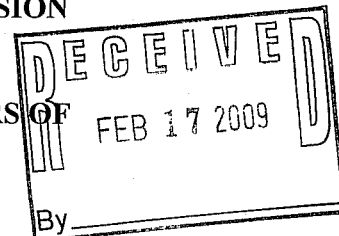

- The Michigan Public Service Commission will be conducting regulatory reviews, revisions, determinations and/or approvals necessary for Consumers Energy Company to fully comply with certain provisions of Public Act 295 of 2008.
- The rates, terms and conditions associated with the implementation of renewable energy and energy optimization plans, among other issues, will be considered in Case Nos. U-15805 and U-15889, which will be conducted on a consolidated basis.
- The information below describes how a person may participate in these cases.
- You may call or write Consumers Energy Company, One Energy Plaza, Jackson, Michigan 49201, (800) 477-5050 for a free copy of its application. Any person may review the documents at the offices of Consumers Energy Company.
- A combined public hearing in these matters will be held:

**DATE/TIME:** February 27, 2009, at 9:00 a.m.  
This hearing will be a prehearing conference to set future hearing dates and decide other procedural matters.

**BEFORE:** Administrative Law Judge Sharon L. Feldman

**LOCATION:** Michigan Public Service Commission  
6545 Mercantile Way, Suite 7  
Lansing, Michigan

**PARTICIPATION:** Any interested person may attend and participate. The hearing site is accessible, including handicapped parking. Persons needing any accommodation to participate should contact the Commission's Executive Secretary at (517) 241-6160 in advance to request mobility, visual, hearing or other assistance.

The Michigan Public Service Commission (Commission) will hold a public hearing to consider Consumers Energy Company's (Consumers Energy) application to be filed by February 18, 2009, seeking approval of its Renewable Energy Plan and its Energy Optimization Plan.

STATE OF MICHIGAN  
BEFORE THE MICHIGAN PUBLIC SERVICE COMMISSION

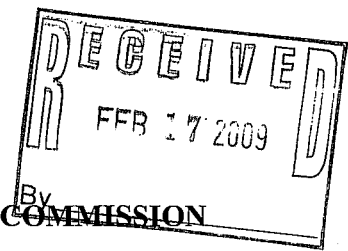

NOTICE OF HEARING  
FOR THE ELECTRIC CUSTOMERS OF  
CONSUMERS ENERGY COMPANY  
CASE NO. U-15744

- Consumers Energy Company will revise previously approved stranded cost recovery surcharges pursuant to Section 10a(16) of Public Act 286 of 2008, if the Michigan Public Service Commission approves its request.
- The information below describes how a person may participate in this case.
- You may call or write Consumers Energy Company, One Energy Plaza, Jackson, Michigan 49201, (800) 477-5050 for a free copy of its application. Any person may review the documents at the offices of Consumers Energy Company.
- The first public hearing in this matter will be held:

**DATE/TIME:** March 3, 2009, at 9:00 a.m.  
This hearing will be a prehearing conference to set future hearing dates and decide other procedural matters.

**BEFORE:** Administrative Law Judge Mark D. Eyster

**LOCATION:** Michigan Public Service Commission  
6545 Mercantile Way, Suite 7  
Lansing, Michigan

**PARTICIPATION:** Any interested person may attend and participate. The hearing site is accessible, including handicapped parking. Persons needing any accommodation to participate should contact the Commission's Executive Secretary at (517) 241-6160 in advance to request mobility, visual, hearing or other assistance.

The Michigan Public Service Commission (Commission) will hold a public hearing to consider the January 16, 2009 application of Consumers Energy Company (Consumers Energy), which seeks approval to modify surcharges and surcharge collection periods for stranded cost recovery surcharges so as to ensure full recovery of all such costs, including reconciliation of cost recovery, to be completed within five years of October 6, 2008, the effective date of Section 10a(16) of Public Act 286 of 2008. Consumers Energy is also requesting authorization to (i) recover the previously approved 2002 and 2003 stranded costs, with interest, from both the Retail Open Access (ROA) and full service customers; (ii) increase the ROA stranded cost recovery surcharge from \$0.001200/kilowatt hour (kWh) to \$0.001866 per kWh; (iii) implement a full service customer stranded cost recovery surcharge of \$0.000666 per kWh; and (iv) continue charging these revised surcharges until the stranded costs, including interest, are fully recovered.

**Paul Bueche**

---

**From:** Genesee County Small Cities and Villages [GCSCV@LISTSERV.MML.ORG] on behalf of Slattery, Robert [RSlattery@GCRC.ORG]  
**Sent:** Thursday, February 12, 2009 11:45 AM  
**To:** GCSCV@LISTSERV.MML.ORG  
**Subject:** Frost Law Weight Restrictions go into effect 2-13-09

## **Frost Law Weight Restrictions**

DATE: February 12, 2009

SUBJECT: Seasonal Weight Restrictions

Effective **6 AM Friday, February 13, 2009**, the Genesee County Road Commission will place seasonal weight and speed restrictions on all county roads within Genesee County. These restrictions will remain in effect indefinitely.

When spring weight restrictions are in effect on frost-restricted routes, axle loadings are reduced by 25 percent on rigid-based roads and 35 percent on flexible-based roads. Most restricted county roads reduce axle loading by 35 percent. Speed limits on frost restricted routes are reduced to 35 mph for every vehicle over 10,000 lbs. gross weight.

No truck, tractor or tractor with trailer, or any combination of such vehicles with a gross weight, loaded or unloaded, in excess of 5,000 pounds shall exceed a speed of 50 miles per hour on highways or streets or 55 miles per hour on freeways. Speed shall be reduced to 35 miles per hour where reduced loadings are being enforced during the period of seasonal weight restrictions.

**See our website ([www.gcrc.org](http://www.gcrc.org)) for a complete list of weight restricted Genesee County roads.** Or call (810) 767-4920 if you have questions.

Bob Slattery



City of  
Swartz  
Creek

**City Offices**

M-F 8am-4:30pm

810.635.4464

810.635.2887 fax

**Police Department**

Emergency 911

M-F 8am-5pm

810.635.4401

810.635.3728 fax

**Public Services Department**

M-F 8am-4:30pm

810.635.4464

Date: February 6, 2009

**To: DDA Board Members**  
**From: Adam Zettel**  
**RE: February 12, 2009 DDA Board Meeting**

Hello everyone,

**There will NOT be a DDA meeting this coming Thursday, February 12, 2009.** We do not have anything pressing to discuss at this time. Immediately following our last meeting, we received a façade grant, and I expect at least one more. With that said, I believe there will not be a need to discuss options on excess expenditures because I suspect there probably will not be any left in this fiscal year.

We will definitely be meeting in March to go over the façade grants and the remainder of the 2009 budget year. I would also like to discuss the Farmers' Market and the 2010 budget at that time.

Please ring me if you have any questions or comments. I am available at City Hall at (810) 635-4464.

Sincerely,

  
Adam Zettel, AICP

Assistant City Manager

(810)-635-4464

[azettel@cityofswartzcreek.org](mailto:azettel@cityofswartzcreek.org)





# 2009 Community Beautification Leadership Conference and 2008 Beautification Awards Program



Saturday, March 7, 2009  
University of Michigan-Flint at the University Center  
Conference 8:00a.m. - 1:00p.m.

## Keep Genesee County Beautiful

is hosting it's fifth annual Community Beautification Conference and Beautification Awards Program on Saturday, March 7, 2009 from 8:00 a.m. – 1:00 p.m. at the University Center on the campus of the University of Michigan – Flint. ★ This year's free conference includes both new and updated workshops that will provide specific "how-to" information and "hands on" projects to help you to build hope where you live, work and play. ★ We are also partnering with several local groups to provide you with more in-depth training in the afternoon. The Applewood Initiative for Community and Gardens, MSU Extension and the Genesee County Land Bank will be hosting the workshop entitled **Urban Gardening: Food for Thought** and UM-Flint University Outreach will be hosting a session on **Growing Volunteers for Your Projects**. ★ Over 20 local organizations will be sharing information and materials at Information Fair booths. ★ Several drawings for beautification and clean up related grand prizes will be held at the end of the morning conference and awards program. ★ Prizes will be provided by the Ruth Mott Foundation – Applewood, Walker Farms & Greenhouse and Keep Genesee County Beautiful.

### Special Conference Recycling Collection – Bring these items with you to drop off!

- ★ Cell Phones
- ★ Old Phone Books
- ★ Rechargeable batteries from power tools
- ★ AA, AAA, C, D batteries (rechargeable and regular)
- ★ Button batteries (small round batteries from calculators, watches, hearing aids, etc.)

### Conference Agenda

- 8:00 – 8:30  
Registration  
*(open throughout conference)*
- 8:30 – 8:50  
Welcome  
*Kay Kelly, President, KGCB  
Karen West, Director, KGCB*
- 9:00 – 10:15  
Workshops Round 1
- 10:15 – 10:30  
Refreshments
- 10:30 – 11:45  
Workshops Round 2
- 12:00 – 12:30  
Beautification Awards  
Program
- 12:30 – 12:45  
Grand Prize Drawings

### Afternoon Workshops

- (pre-registration required)*
- 1:00 – 3:30  
Urban Gardening: Food for  
Thought
- 1:00 – 4:00  
Growing Volunteers for  
Your Projects

Keep Genesee County Beautiful is the first affiliate of Keep America Beautiful in the State of Michigan and is funded by the Ruth Mott Foundation in partnership with the United Way of Genesee County and University of Michigan – Flint University Outreach.

# Morning Workshops

## Information Fair Participants

As of January 26, 2009 the following organizations have agreed to host a table and provide information and materials to conference attendees.

Applewood Initiative for Gardening and Community

AT&T

CBC Recycling

City of Flint – Neighborhood Clean Up Programs

Flint River Corridor Alliance

Flint River Wild Ones

Fox 66 Green Team

Genesee Area Landscape & Nursery Association

Genesee Conservation District

Genesee County Health Department – Division of Environmental Health Services

Genesee County Land Bank

Genesee County Metropolitan Planning Commission

Genesee County Parks & Recreation Commission

Genesee Regional Trail Council

IMA Parks and Recreation

Keep Genesee County Beautiful

MSU Extension

Salem Housing CDC

UAW Local 599 – Environmental Committee

Walker Farms

WoJo's Nursery

## Composting

### **Turning Garbage into Gold for Growing Your Garden**

*Phil Downs, Master Composter*

Learn how to turn kitchen waste and yard waste into an excellent soil amendment to help your garden grow. Phil will discuss different methods and bins to use for composting and how to add it to your garden.

## Grant Writing

### **Grant Writing for 2009 Beautification Mini Grants**

*Lynn Larkin, Community Foundation of Greater Flint  
Chris Monk, Keep Genesee County Beautiful*

This workshop will review the grant application form that will be used for the 2009 Beautification Mini Grants offered through Keep Genesee County Beautiful. Participants will receive advice on how to fill out the application form as well as learn about the new requirements for this year's projects.

## Perennial Care

### **Perennials: Nature's Reruns**

*Claudia Mach, Applewood Initiative for Gardening and Community  
Kelly Care, Applewood Horticulturist*

Like old friends perennial flowers reappear every spring. Although most are easily cared for, there are some simple requirements to keep them maintained. Let the dynamic divas, Claudia and Kelly teach you about the basic techniques of selection, planting, staking, deadheading and dividing these wonderful plants! Learn their favorites and must-haves in every perennial garden!

## Pest Management

### **What's Bugging You? Understanding Pests in the Garden**

*Terry McLean, MSU Extension-Genesee County Horticulture Educator/Master Gardener Coordinator  
Deborah Elliott, Applewood Horticulturist/Estate Manager*

Learn the basics of pest management in the garden, including how to attract the good guys, and other environmentally friendly tips for pest control.

## Recycling

### **Reduce Your Waste**

*Holly Lubowicki, Keep Genesee County Beautiful  
Dan Emerton, UAW Local 599 – Environmental Committee  
Stephanie Rieschling, CBC Recycling*

Recycling is NOT just for those with curbside collection programs. Learn how to put less in your trash can and recycle more. We will take you full circle and discuss how to set up a system in your home, hear about the "dollars and sense" of recycling, where to recycle and check out products made from recycled goods. You will find out how to identify and properly dispose of hazardous waste and electronic waste. Want to become a green team member? We can tell you how.

## Traditional and Non-Traditional Volunteer Recruitment

### **Can You Hear Me Now?**

*Thom Clark, Chicago's Community Media Workshop  
Linda Bedtelyon, Applewood Volunteer Coordinator  
Roxy Moreno, Community Volunteer*

If your cries for volunteers keep hitting dead zones, this panel will help you make a clearer connection. Join Thom Clark of Chicago's Community Media Workshop and local volunteer coordinators to find out ways to reach new volunteers and revitalize your group. They'll discuss traditional media, such as newspapers, and new media, such as social Internet networking.

## Tree Care

### **10 Ways to Kill Your Tree**

*Brian VanPatten, Horticulturist  
Genesee County Parks & Recreation Commission*

People put a lot of time and care into their new trees; unfortunately, their good intentions can be in the worst interest of the tree. We will take a look at the most common tree care mistakes and show you how to avoid or correct them.

## Vegetable Gardens

### **Growing Food in Our Community**

*Erin Caudell, Applewood Horticulturist  
Jacky and Dora King, Youth Karate Ka  
Harvesting the Earth Farm  
Greg Gaines, Mr.. Rogers Just Say No Program*

Why is growing our own food becoming so important? Hear about several cool local projects that are successfully growing vegetables in urban areas.







# Keep Genesee County Beautiful

announces the fifth annual

## **Community Beautification Leadership Conference and 2008 Beautification Awards Program**



Saturday, March 7, 2009

Morning Workshops

8:00 a.m. to 1:00 p.m.

University of Michigan – Flint at the University Center

Afternoon Workshops

Urban Gardening: Food for Thought – 1:00p.m. - 4:00p.m.

Growing Volunteers for Your Projects – 1:00p.m. - 4:00p.m.

Information Fair: Over 20 local organizations involved in clean up, beautification and recycling activities and projects.

- Composting • Grant Writing • Perennial Care • Pest Management • Recycling
- Traditional and Non-Traditional Volunteer Recruitment • Tree Care • Vegetable Gardens

**DEADLINE IS MARCH 4 FOR THE CONFERENCE AND MARCH 2 FOR THE AFTERNOON WORKSHOPS**

For more information or to be added to the mailing list, contact Keep Genesee County Beautiful  
Phone: 810-767-7184 • Fax: 810-424-5484 • Email: karenwest@umflint.edu



48473#1498 C002

CITY OF SWARTZ CREEK  
8083 CIVIC DR  
SWARTZ CREEK MI 48473-1498

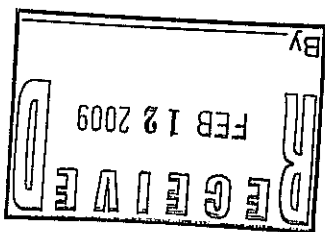

**Deadline is  
March 4 for the conference  
March 2 for the afternoon workshops**

Keep Genesee County Beautiful  
432 N. Saginaw St. • Suite 1001  
Flint, MI 48502

First-Class Mail  
U.S. Postage  
PAID  
TGI Direct

**The Genesee County Board of Commissioners**

**cordially invites you to attend the**

**“STATE OF THE COUNTY”  
ADDRESS**



**Delivered by**

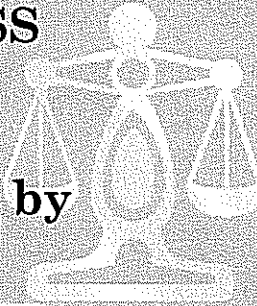

**Ted Henry  
Board Chairperson**

**Wednesday, February 25, 2009**

**5:15 P.M.**

**Harris Auditorium  
Genesee County Administration Building**

**1101 Beach Street, Flint, MI**



ROOM 223 - 1101 BEACH STREET

FLINT, MICHIGAN 48502-1470

TELEPHONE (810) 257-3010 FAX (810) 257-3185

JULIE A. HINTERMAN  
DIRECTOR-COORDINATOR

**FAX COVER SHEET**

NUMBER OF PAGES (including this page): 2

IF YOU DO NOT RECEIVE ALL OF THE PAGES, PLEASE CALL (810) 257-3010 AS SOON AS POSSIBLE.

TO: City Managers, Mayors, Presidents,  
Supervisors of all local units

FAX # \_\_\_\_\_

FROM: Alberta  
FAX # (810) 257-3185

DATE: February 18, 2009

TIME: 2:17 p.m.

COMMENTS: Please let your Council people  
know.

Thank You!



ROOM 223 – 1101 BEACH STREET

FLINT, MICHIGAN 48502-1470

TELEPHONE (810) 257-3010 FAX (810) 257-3185

JULIE A. HINTERMAN  
DIRECTOR-COORDINATOR

**Governor Granholm to speak at  
Mass Transportation Authority offices  
on economic stimulus bill**

**What:** Governor Granholm to speak at Mass Transportation offices on economic stimulus bill

**When:** Thursday, February 19, 2009 (3:30 p.m.)

**Where:** Mass Transportation Authority  
Administration Building  
1401 S Dort Highway  
Flint, MI, 48502

You are cordially invited to hear Governor Jennifer Granholm discuss how the economic stimulus bill will impact transportation in Michigan. Please join us this Thursday, February 19, 2009 (presentation begins at 3:30 p.m.); we will be greeting guests beginning at 3:00 p.m. at MTA Administration Building 1401 S Dort Highway, Flint Michigan

Genesee County Metropolitan Planning Commission Director Coordinator, Julie Hinterman will talk about the process for submitting transportation projects and what this means for Genesee County.

AN EQUAL OPPORTUNITY ORGANIZATION



**BOARD COORDINATOR  
GENESEE COUNTY BOARD OF COMMISSIONERS**

1101 BEACH STREET, ROOM 312  
FLINT, MICHIGAN 48502

TELEPHONE: (810) 257-3020  
FAX: (810) 257-3008

Wednesday, February 18, 2009

Memo

To: Local Units of Government

From: Dan Harrell, Board Coordinator   
Genesee County Board of Commissioners

Re: Stimulus Package Information Meeting

We have been informed that Governor Jennifer Granholm is making a tour of Michigan to discuss the Stimulus Package with local leaders. She will be in Flint on Thursday, February 19, 2009, 3:30 PM, at the Mass Transportation Authority Basement Conference Room, 1401 South Dort Highway, Flint.

She will be discussing the transportation and other portions of the recently passed Stimulus Package, and how that package can impact local units of government.

All local officials are invited to attend.

stimulus0218memo

## Paul Bueche

---

**From:** Michigan Municipal League [nbrown@mml.org]  
**Sent:** Tuesday, February 10, 2009 4:46 PM  
**To:** Paul Bueche  
**Subject:** MML Legislative Link 2-10-2009



February 10, 2009

### State Affairs Report

#### League Releases its Prosperity Agenda, Presented to Legislative Committees Today –

The League today released its [Prosperity Agenda](#), which details the new direction of the League and outlines public policies that — if approved — would create new jobs in the state, generate new commercial and residential investments and create the types of communities Michigan needs to prosper once again. League Executive Director and CEO, Daniel P. Gilmartin, presented the Prosperity Agenda to the [House Intergovernmental and Regional Affairs Committee](#) and [Senate Commerce and Tourism Committee](#) this afternoon. Contact: [Andrea Messinger](#)

#### House Committee Takes up Retiree Bonding Bills –

Wednesday the House Judiciary Committee is taking up HBs [4074](#), [4075](#), and [4077](#) which allow local units of government to bond for other post employment benefits (OPEB) liabilities. These bills had passed House committee last session but failed to make it off the House floor. The League is supporting the legislation and is urging passage. Contact: [Summer Minnick](#)

**Hire Michigan First Legislation –** The House Commerce Committee today passed of bills that would require any tax dollars go to companies that hire Michigan citizens first. For locals, this affects [Brownfields](#), [OPRA abatements](#), [renaissance zones](#), [MEGAs](#), [PA 198 Industrial Facilities Tax abatements](#), [Industrial Development Revenue Bonds](#), and dollars that the state gives out. Rep. Fred Miller (D-Mt Clemens) testified on the importance of getting dollars back into the hands of Michigan employees and employers. Some opponents had issues with these bills and claimed that they will increase costs. The House last year amended these bills to satisfy concerns from the League, and we do not have an official position at this time. We will continue to track this legislation. The bills are expected to be voted on this week. Contact: [Andy Schor](#)

### The Buzz

[Property Taxes Pay for Critical Services](#)

LSJ 2/5/09

### What's New

[Blogger Offers Insight on Making Millenials Feel at Home in Your Community](#)

[Make it Easier for Local Government to Save Cash](#)

[Two Thumbs Up: Mass Transit Now](#)

[Inside 208, the League's New Blog](#)

[2009 National Preservation Award](#)

[Nominations](#)

Submit entries by March 2

### Save the Date

[53rd Annual Asphalt Pavement Association of Michigan Conference](#) Feb. 25-26, Lansing

[Concrete Repair Seminar](#)  
Jan. 28, Howell  
June 4, Marquette

[EOA Core Weekender](#) &

**State Budget Presentation on Thursday** – Thursday at 11 am, Bob Emerson, Director of the Office of the State Budget, will present the 2010 state budget to a joint House and Senate Appropriations Committee meeting. Stay tuned to the [Inside 208](#) blog for further details. Contact: [Summer Minnick](#)

**Federal Recovery Plan a Capital Conference "Hot Topic"** – With an influx of federal money en route to states and local communities for infrastructure projects, shouldn't you understand the new funding programs? Capital Conference has you covered; join us March 3-4 in Lansing as transportation and infrastructure experts explain these programs and how the country should approach its long-term infrastructure needs. Visit [Capital Conference](#) for details and registration.

**Michigan Humanities Council Grants/Events** – Are you looking for a grant to help bring an artist or musician to your community? Are you looking for a public humanities grant? The Michigan Humanities Council can help you. [Click here](#) for more information on their grants as well as a listing of their upcoming events.

**Local Bridge Programs Applications** – In a letter dated February 4, 2009, the League has received word that MDOT is looking for local bridge projects for funding through the Local Bridge Program. Selected projects would receive funding for Fiscal Year 2012. [Click here](#) for the full letter and application packet. It is important to remember that bridge replacement, rehabilitation, or preventive maintenance projects are eligible for funding and that each agency is limited to a total of 5 applications only. All applications must be postmarked no later than June 1, 2009. Contact: Mark Harrison (MDOT Bridge Program Manager) at 517-373-2346/harrisonm@michigan.gov.

**53rd Annual Asphalt Pavement Association of Michigan Conference** – The 53rd Annual APAM Conference will be held February 25-26 at the Radisson Plaza Hotel in Kalamazoo, MI. This will be a good opportunity for public works officials and employees to learn about the use of asphalt in local road projects, as well as finding out the latest on Michigan's transportation funding situation. [Click here](#) for registration information (\$140 before 2/20/09; \$150 on site).

## Federal Update

**Senate Approves Stimulus Bill, Conference Committee Next** – Today, by a vote of 61-37, the Senate approved the American Recovery and Reinvestment act. The bill now goes to a House/Senate conference committee for negotiation. An [updated chart](#) shows the differences between the two versions. Amendments approved by the Senate cut funding for several programs, including the Neighborhood Stabilization Program, Byrne/JAG Justice Grants as well as

[Advanced Weekender](#)  
Feb. 20-21, Frankenmuth

[Capital Conference](#)  
March 3-4, Lansing ([EOA](#))  
*Early-bird rates end Feb. 9*

[Essential Skills for Elected Officials](#)  
March 3, Lansing ([EOA](#))

[Saving Money through Risk Management](#)  
March 3, Lansing ([EOA](#))

[Making MI. a Box Office Hit](#)  
March 3, Lansing ([EOA](#))

[MI Municipal Attorneys Annual Advanced Institute](#)  
March 3, Lansing

[Stormwater Management Conference](#)  
March 10-13, Bay City

[Regional Seminars](#)  
Friday's April - June,  
Seven Locations  
Statewide ([EOA](#))

## Grants & Projects

[Local Bridge Programs Applications](#)  
*Apply by June 1*

[Michigan Humanities Council Grants/Events](#)

[MI Coastal Management Program Seeks Projects](#)  
*Apply by 4 p.m. Feb. 13*

[MI Housing Community Development Funds](#)

[High Risk Rural Roads](#)  
*Apply by Feb. 27*

[Safety Program Projects](#)  
*Apply by March 27*

[Federal Brownfield Funding](#)



health and education programs. Keep up to date over the coming days through the [Inside 208](#) blog and the League's [federal webpage](#). Contact: [Arnold Weinfeld](#)

**Digital Television Transition Delayed** – As reported on the League website last week, the U.S. Congress has passed legislation, [S. 352](#), which will delay the digital transition for television until June 12. The bill also permits consumers who never redeemed coupons to reapply for replacement coupons, provided that no household can redeem more than two coupons; preserves the ability of broadcasters to transition before the new transition date, if such a move does not interfere with another broadcast signal; and, preserves the ability of public safety entities to use DTV spectrum before the new transition date, subject to FCC rules. Contact: [Arnold Weinfeld](#)

#### Related Links

[MI Legislature](#)

[MI Senate](#)

[MI House of Reps](#)

[Resources](#)

## Email Management

The Michigan Municipal League respects your right to privacy.

[Click here](#) to unsubscribe.

[Click here](#) to manage your Michigan Municipal League email subscription preferences.

If you no longer wish to receive any type of email notice from the Michigan Municipal League, [please click here](#).

---

Michigan Municipal League, 1675 Green Road, Ann Arbor, MI 48105



## Paul Bueche

---

**From:** Michigan Municipal League [nbrown@mml.org]  
**Sent:** Tuesday, February 17, 2009 2:45 PM  
**To:** Paul Bueche  
**Subject:** MML Legislative Link 2-17-09



February 17, 2009

### State Affairs Report

#### Revenue Sharing Left Untouched in Gov.'s Budget

– Last week, the Governor released her executive budget proposing local units of government receive the same amount of funding as last year (retaining the increase from last year). Although this is a far cry from the monies we are suppose to be receiving, the fact that we are not being cut this year is notable. As the state budget experiences a \$1.4 billion shortfall, many institutions, including higher education, found themselves on the chopping block. In the future, hopefully we will be able to salvage some of the monies we have lost. Contact: [Summer Minnick](#)

**Capital Conference Details Online Now** – With details about the [program now online](#), see for yourself what Capital Conference, March 3-4 in Lansing, has in store for local officials this year! Whether you're new, practiced, elected or appointed, we've stacked the program so there's something for everyone. With so many sessions to choose from (Saving Money through Risk Management, The Impact of New FMLA Regulations and The View from Capitol Hill to name a few) you can tailor your very own Capital Conference schedule and get the most out of these action-packed days in Lansing. Check out [Capital Conference](#) and register today!

**Comments Needed to Preserve PEG** – The Federal Communications Commission (FCC) has [opened a case](#) on preserving the quality and financial viability of public, education and government (PEG) channels. This case follows on the heels of litigation by several of Michigan's communities, including Meridian Township, Dearborn and the City of Lansing, seeking to preserve the quality of PEG. Comments are needed from as many municipalities as possible to thwart arguments from cable that keeping PEG is not important. The comments are due by March 9, and can be found in the FCC's public notice. Contact: [Samantha Harkins](#)

### The Buzz

[Infrastructure Rates Highest for Stimulus](#)  
 LSJ 2/16/09

### What's New

[Cisco Unveils Global Blueprint for Cities](#)

[Blogger Offers Insight on Making Millenials Feel at Home in Your Community](#)

[Make it Easier for Local Government to Save Cash](#)

[Inside 208, the League's New Blog](#)

[2009 National Preservation Award Nominations](#)  
 Submit entries by March 2

### Save the Date

[Sustainable Lighting Solutions for Local Governments](#)  
 Feb. 26

[53rd Annual Asphalt Pavement Association of Michigan Conference](#) Feb. 25-26, Lansing

## League Presents Prosperity Agenda to House

**Trans Committee** – Last Thursday, the League presented our [Prosperity Agenda](#) to the House Transportation Committee. The committee members were very responsive and understood that if Michigan is going to prosper, we need to significantly expand public transit in Michigan, enact recommendations of the Transportation Funding Task Force report, protect public safety and other essential local services, use federal stimulus funds to restore local infrastructure first, and promote sustainable development, green initiatives and cultural economic development. Contact: [David Worthams](#)

**1,000 Nights Kickoff a Success** – Last week the League hosted an event to kickoff 1,000 nights of activities in Lansing, a campaign targeted toward legislative staff. The concept of 1,000 nights is that people are getting married later. They graduate from college at 22 and get married when they're 32 and in that ten years there needs to be something fun to do at least 2 nights a week (equal to 1,000 nights) or young people will move someplace that has the amenities they are looking for. This is an economic argument to keep and attract talent to communities. As part of our lobbying effort, the League is encouraging legislative staff to show us 1,000 nights of fun in the Lansing community. Contact: [Samantha Harkins](#)

**New Legislator Luncheon** – The League hosted a New Legislator Luncheon last week for all of the newly elected representatives. Freshman lawmakers became better acquainted with the League and our president and vice president at a luncheon in our Capital Office. For some of them it was perhaps their first face-to-face with your association and we look forward to building these relationships in the coming months. Contact: [Andrea Messinger](#)

**Downtown Workshop Webinar** – The STARS Division of MSHDA is planning a special webinar so that those who could not make it to the workshops around the state can still learn about the changes and improvements to the Division's programs. The webinar is scheduled for Wednesday, February 25 from 1-4pm. Attached you will find an [agenda](#) and [instructions](#) on how to log on. Those wishing to participate are asked to RSVP with [Linda Best](#) or by phone at (517) 373-8999.

## Michigan Housing Preservation Network Awards

– The Michigan Housing Preservation Network (MHPN) is accepting nominations for the 2009 Preservation Awards until February 27th. There are several categories including one for communities that have accomplished significant steps to engage in a plan for historic preservation. Visit the [MHPN website](#) to download the nomination form and get further details.

**See the Light, Save the Money** – The Southeast Michigan Regional Energy Office, a collaborative project of the League, Michigan Suburbs Alliance, SEMCOG and WARM Training Center, is holding a seminar on February 26th on "Sustainable Lighting Solutions for Local Governments". The program, which will be held from 12:30 pm to 4:00 pm at the

## [Concrete Repair Seminar](#)

Jan. 28, Howell  
June 4, Marquette

## [EOA Core Weekender & Advanced Weekender](#)

Feb. 20-21, Frankenmuth

## [Capital Conference](#)

March 3-4, Lansing (EOA)  
*Early-bird rates end Feb. 9*

## [Essential Skills for Elected Officials](#)

March 3, Lansing (EOA)

## [Saving Money through Risk Management](#)

March 3, Lansing (EOA)

## [Making MI. a Box Office Hit](#)

March 3, Lansing (EOA)

## [MI Municipal Attorneys Annual Advanced Institute](#)

March 3, Lansing

## [Stormwater Management Conference](#)

March 10-13, Bay City

## [Regional Seminars](#)

Friday's April - June,  
Seven Locations  
Statewide (EOA)

## Grants & Projects

## [Michigan Historic Preservation Awards](#)

*Apply by Feb 27*

## [Local Bridge Programs Applications](#)

*Apply by June 1*

## [Michigan Humanities Council Grants/Events](#)

## [MI Housing Community Development Funds](#)

## [High Risk Rural Roads](#)

*Apply by Feb. 27*

Engineering Society of Detroit's new offices in Southfield, will feature information on upgrading street lighting and retrofitting building lighting. Registration is free for members of MML, SEMCOG, Michigan Suburbs Alliance, US Green Building Council Detroit Regional Chapter and ESD. [Click here](#) to register.

[Safety Program Projects](#)  
*Apply by March 27*

[Federal Brownfield Funding](#)

#### Related Links

[MI Legislature](#)

[MI Senate](#)

[MI House of Reps](#)

[Resources](#)

## Federal Update

**Stimulus Bill Passes** – HR 1, the American Recovery and Reinvestment Act, was passed by the U.S. Congress late last week and is expected to be signed into law by the President today. The bill contains \$789 billion in funding for infrastructure, housing, public safety, health and renewable energy programs as well as tax cuts. Michigan's share appears to be about \$7 billion over the next two years, although given the bill's 1000+ page length, final figures and how funds are to be distributed and regulated are still being reviewed. At this point though it looks like the state will see \$847 million for highways and bridges of which \$593 million will go to MDOT and \$254 million to everyone else. There is also money for transit capital grants in the amount of \$145 million. We will receive \$239 million for sewer and water projects; \$68 million for drinking water and \$171 million for clean water. States will have 120 days after apportionment (apportionment must be made within 21 days of the law's enactment) to obligate the first 50 percent of their highway apportionments and until one year after apportionment to obligate the remainder. Hopefully the state Legislature will now be helpful, where it can, to make sure these monies get out as fast as possible. Contact: [Arnold Weinfeld](#)

## Email Management

The Michigan Municipal League respects your right to privacy.

[Click here](#) to unsubscribe.

[Click here](#) to manage your Michigan Municipal League email subscription preferences.

If you no longer wish to receive any type of email notice from the Michigan Municipal League, [please click here](#).

---

Michigan Municipal League, 1675 Green Road, Ann Arbor, MI 48105